

### Features

- Digital microphone support
- High efficiency Class-D amplifier
- Ultra Low power consumption
- 16 bit audio data
- Supports conventional telephony and HD voice (300Hz - 3.4kHz and 50Hz -7kHz bandwidths)
- Supports audio bandwidths up to 21kHz
- Supports 8/16/32/48 kbps sample rates
- Flexible serial audio interface
- SPI™/TWI control interface<sup>1</sup>
- Small 24-lead VQFN Package

### Applications

- Security alarm panels
- Glass break detection
- Intercom and access systems
- Mobile radio and accessories
- Wired telephony
- Voice controlled equipment

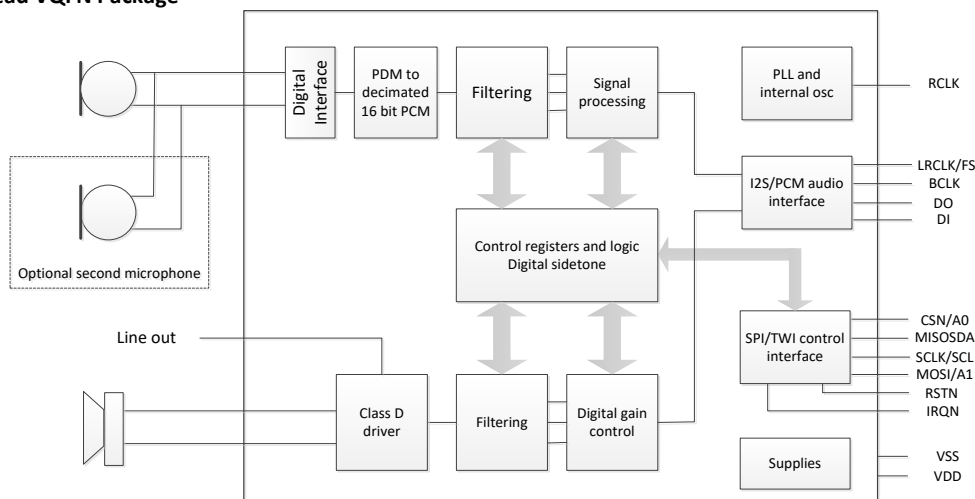


Figure 1 CMX655D Simplified Block Diagram

## 1 Brief Description

Traditionally audio codecs have interfaced to electret microphones and speakers providing A-to-D and D-to-A functions using precision oversampling data converters. Recent advances in microphone design using MEMS techniques are now changing this, along with higher efficiency speaker drivers such as Class-D topologies. Both of these advances enable significant reductions in power consumption which is needed to address new applications such as voice control, that require ‘always-on’ operation. Such applications are often battery powered, driving the need for minimal power consumption. The CMX655D addresses these needs providing an update to the traditional audio codec that is both very low power and small in size.

The CMX655D has a digital microphone interface that connects single or dual microphones to the device and the same parallel processing streams.

A 1-Watt mono Class-D amplifier drives differential audio outputs for a filterless speaker. A separate single-ended analogue lineout is also provided for a headphone. The Class-D amplifier features programmable filtering and digital gain control. This architecture operates with far higher efficiency than conventional speaker drivers.

The device interfaces via standard serial busses that are commonly found on many microcontrollers, DSPs and low cost radio transceivers.

<sup>1</sup> SPI™ is a trademark of Motorola Inc.

**Contents**

| <u>Section</u> |  | <u>Page</u> |
|----------------|--|-------------|
| <b>1</b>       | <b>Brief Description</b> .....         | <b>1</b>    |
| <b>2</b>       | <b>Block Diagram</b> .....             | <b>5</b>    |
| 2.1            | CMX655D.....                           | 5           |
| <b>3</b>       | <b>Pin List</b> .....                  | <b>6</b>    |
| 3.1            | CMX655D.....                           | 6           |
| <b>4</b>       | <b>External Components</b> .....       | <b>9</b>    |
| 4.1            | CMX655D.....                           | 9           |
| 4.1.1          | Power Supply and Pin Decoupling.....   | 9           |
| 4.1.2          | SPI.....                               | 10          |
| 4.1.3          | TWI .....                              | 11          |
| 4.1.4          | Speaker and Microphone .....           | 12          |
| <b>5</b>       | <b>General Description</b> .....       | <b>13</b>   |
| 5.1            | Power Management.....                  | 13          |
| 5.1.1          | External Supplies .....                | 13          |
| 5.1.2          | Regulated Supplies .....               | 13          |
| 5.2            | Device Reset .....                     | 13          |
| 5.2.1          | Power-On-Reset .....                   | 13          |
| 5.2.2          | Reset Pin.....                         | 13          |
| 5.3            | Main Clock.....                        | 14          |
| 5.3.1          | Clock Frequency .....                  | 14          |
| 5.3.2          | Clock Generation .....                 | 14          |
| 5.3.3          | PLL .....                              | 15          |
| 5.3.4          | Low Power Oscillator.....              | 16          |
| 5.3.5          | Clock Control Registers.....           | 16          |
| 5.4            | Microphone Interface .....             | 18          |
| 5.4.1          | Digital Microphone Interface .....     | 18          |
| 5.5            | Class-D Amplifier .....                | 18          |
| 5.5.1          | Audio Outputs .....                    | 18          |
| 5.5.2          | Overload Current Protection .....      | 18          |
| 5.5.3          | Thermal Protection.....                | 18          |
| 5.5.4          | Clipping Detection .....               | 18          |
| 5.6            | Audio Signal Processing.....           | 19          |
| 5.6.1          | Record Level Control .....             | 19          |
| 5.6.2          | Noise Gate .....                       | 19          |
| 5.6.3          | Record Level Detection .....           | 22          |
| 5.6.4          | Playback Preamplifier Gain.....        | 23          |
| 5.6.5          | Playback Volume Control .....          | 24          |
| 5.6.6          | Automatic Level Control.....           | 25          |
| 5.6.7          | Digital Sidetone .....                 | 27          |
| 5.6.8          | Voice Filters.....                     | 28          |
| 5.6.9          | Channel Multiplexing .....             | 30          |
| 5.6.10         | Click-and-Pop Reduction .....          | 30          |
| 5.7            | Control Interface .....                | 31          |
| 5.7.1          | SPI Slave .....                        | 31          |
| 5.7.2          | TWI Slave.....                         | 32          |
| 5.8            | Serial Audio Interface .....           | 35          |
| 5.8.1          | I2S Mode .....                         | 35          |
| 5.8.2          | Left-Justified Mode.....               | 35          |
| 5.8.3          | PCM Mode.....                          | 36          |
| 5.8.4          | Audio Companding.....                  | 37          |
| 5.8.5          | Serial Audio Interface Registers ..... | 38          |
| 5.9            | Interrupt Status and IRQN Pin .....    | 39          |
| 5.9.1          | Interrupt Registers .....              | 39          |
| 5.10           | System Control .....                   | 40          |
| 5.10.1         | System Control Registers.....          | 40          |
| 5.11           | Register Address Map .....             | 41          |
| <b>6</b>       | <b>Application Notes</b> .....         | <b>43</b>   |

|          |   |           |
|----------|---|-----------|
| 6.1      | Programming Examples.....                   | 43        |
| 6.1.1    | Start-up .....                              | 43        |
| 6.1.2    | Configuration.....                          | 44        |
| 6.1.3    | Enable Audio Channels.....                  | 45        |
| 6.1.4    | Shutdown .....                              | 45        |
| <b>7</b> | <b>Performance Specification .....</b>      | <b>47</b> |
| 7.1      | Electrical Performance .....                | 47        |
| 7.1.1    | Absolute Maximum Ratings .....              | 47        |
| 7.1.2    | Operating Limits .....                      | 47        |
| 7.1.3    | Operating Characteristics .....             | 48        |
| 7.2      | Typical Performance Characteristics .....   | 55        |
| 7.2.1    | THD+N vs. Level performance .....           | 55        |
| 7.2.2    | THD+N vs. Frequency performance.....        | 58        |
| 7.2.3    | Class D Amplifier Efficiency .....          | 60        |
| 7.2.4    | Filter Performance Speaker Channel.....     | 61        |
| 7.2.5    | Filter Performance Microphone Channel ..... | 63        |
| 7.3      | Packaging.....                              | 65        |
| 7.3.1    | CMX655D.....                                | 65        |

| <u>Table</u> |   | <u>Page</u> |
|--------------|---|-------------|
| Table 1      | CMX655D Pin List by Number .....                | 6           |
| Table 2      | CMX655D Pin List by Group .....                 | 7           |
| Table 3      | CMX655D Component Values .....                  | 9           |
| Table 4      | CMX655D SPI Component Value.....                | 10          |
| Table 5      | CMX655D TWI Component Values.....               | 11          |
| Table 6      | External Supply Voltages.....                   | 13          |
| Table 7      | Supply and POR Threshold Voltages .....         | 13          |
| Table 8      | CMX655D Slave Addresses .....                   | 32          |
| Table 9      | Register Address Map .....                      | 41          |
| Table 10     | SPI Timing Parameter Values .....               | 51          |
| Table 11     | TWI Standard Mode Timing Parameters .....       | 52          |
| Table 12     | TWI Fast Mode Timing Parameters.....            | 53          |
| Table 13     | TWI Pull-up Resistors and Bus Capacitance ..... | 53          |
| Table 14     | SAI Timing Parameters .....                     | 54          |
| Table 15     | Digital Microphone Timing Parameters .....      | 54          |

| <u>Figure</u> |  | <u>Page</u> |
|---------------|--|-------------|
| Figure 1      | CMX655D Simplified Block Diagram .....   | 1           |
| Figure 2      | CMX655D Block Diagram .....  | 5           |
| Figure 3      | CMX655D Pin Arrangement.....   | 8           |
| Figure 4      | CMX655D Power Supply and Pin Decoupling .....  | 9           |
| Figure 5      | CMX655D SPI Connections.....   | 10          |
| Figure 6      | CMX655D TWI Connections.....   | 11          |
| Figure 7      | CMX655D Speaker and Microphone Connections .....   | 12          |
| Figure 8      | Main Clock Generation .....  | 14          |
| Figure 9      | Integer-N PLL .....  | 15          |
| Figure 10     | PLL Loop Filter.....   | 15          |
| Figure 11     | CMX655D Digital Microphone Interface .....   | 18          |
| Figure 12     | Audio signal processing block diagram with gain level block highlighted.....                     | 19          |
| Figure 13     | Audio signal processing block diagram with Noise Gate block highlighted .....                    | 19          |
| Figure 14     | Noise Gate Response .....  | 20          |
| Figure 15     | Audio signal processing block diagram with Level Detect block highlighted .....                  | 22          |
| Figure 16     | Audio signal processing block diagram with preamp block highlighted .....                        | 23          |
| Figure 17     | Audio signal processing block diagram with the volume block highlighted.....                     | 24          |
| Figure 18     | Audio signal processing block diagram with ALC block highlighted .....                           | 25          |
| Figure 19     | ALC Response.....  | 25          |
| Figure 20     | Audio signal processing block diagram with the Digital Side Tone path and block highlighted..... | 27          |
| Figure 21     | Audio signal processing block diagram with Voice Filter blocks highlighted .....                 | 28          |
| Figure 22     | Low Pass Filter Frequency Response .....   | 28          |
| Figure 23     | High Pass Filter Frequency Response.....   | 29          |

|  |    |
|--|----|
| Figure 24 Audio signal processing block diagram with Mic Mux and Amp Mux block highlighted ..... | 30 |
| Figure 25 SPI Write Transfer .....   | 31 |
| Figure 26 SPI Read Transfer .....  | 31 |
| Figure 27 SPI N-Byte Write Transfer .....  | 32 |
| Figure 28 SPI N-Byte Read Transfer .....   | 32 |
| Figure 29 TWI Write Transfer .....   | 33 |
| Figure 30 TWI Read Transfer Address Phase .....  | 33 |
| Figure 31 TWI Read Transfer Data Phase.....  | 34 |
| Figure 32 TWI Interrupt Status Register Read Transfer .....                                      | 34 |
| Figure 33 TWI N-Byte Write Transfer .....  | 34 |
| Figure 34 TWI N-Byte Read Transfer.....  | 34 |
| Figure 35 I2S Mode Data Transfer .....   | 35 |
| Figure 36 Left-Justified Mode Data Transfer .....  | 36 |
| Figure 37 PCM Mode Dual-channel Data Transfer .....  | 36 |
| Figure 38 PCM Mode Single-channel Data Transfer .....  | 37 |
| Figure 39 PCM Slave Mode Dual-channel Companded Data Transfer .....                              | 37 |
| Figure 40 SPI Timing Diagram .....   | 51 |
| Figure 41 TWI Timing Diagram .....   | 52 |
| Figure 42 SAI Timing Diagram .....   | 54 |
| Figure 43 Digital Microphone Timing Diagram .....  | 54 |
| Figure 44 Class D amplifier THD+N vs. Level 48ksps .....   | 55 |
| Figure 45 Class D amplifier THD+N vs. Level 32ksps .....   | 55 |
| Figure 46 Class D amplifier THD+N vs. Level 16ksps .....   | 56 |
| Figure 47 Class D amplifier THD+N vs. Level 8ksps .....  | 56 |
| Figure 48 Line out amplifier THD+N vs. Level 48/32/16/8ksps.....                                 | 57 |
| Figure 49 Class D amplifier THD+N vs. Frequency 48ksps .....                                     | 58 |
| Figure 50 Class D amplifier THD+N vs. Frequency 32ksps .....                                     | 58 |
| Figure 51 Class D amplifier THD+N vs. Frequency 16ksps .....                                     | 59 |
| Figure 52 Class D amplifier THD+N vs. Frequency 8ksps .....                                      | 59 |
| Figure 53 Line out amplifier THD+N vs. Frequency 48/32/16/8ksps .....                            | 60 |
| Figure 54 Class D amplifier efficiency 4 $\Omega$ .....  | 60 |
| Figure 55 Class D Amplifier Efficiency 8 $\Omega$ .....  | 61 |
| Figure 56 Low Pass Filter Response Speaker Channel .....   | 61 |
| Figure 57 High Pass Filter Response Speaker Channel.....   | 62 |
| Figure 58 Low Pass Filter response Microphone Channels.....                                      | 63 |
| Figure 59 High Pass Filter Response Microphone Channels .....                                    | 64 |
| Figure 60 VQFN-24 Mechanical Outline (Q6).....   | 65 |

## History

| Version | Changes   | Date                           |
|---------|---|--------------------------------|
| 1       | Document title changed to “CMX655D/CMX655A Ultra Low-Power Codec”<br>Section 7.2 – Typical Performance Characteristics graphs added<br>Section 5.6.7 – Automatic Level Control: description and associated register tables<br>“greyed out” pending further revision | 8 <sup>th</sup> August 2018    |
| 2       | Revised performance figures   | 3 <sup>rd</sup> September 2018 |
| 3       | First public release  | 19 <sup>th</sup> October 2018  |
| 4       | All references to CMX655A removed   | 22 <sup>nd</sup> October 2019  |
| 5       | Section 6.1.1: App Notes – Start-up programming example revised to achieve lowest power consumption.<br>Section 7.1.3.1: Revised typical current consumption to 260 $\mu$ A when using RCLK mode.   | 1 <sup>st</sup> October 2020   |
| 6       | Section 4.1.1 – Power Supply and Pin Decoupling: C6 and C7 added to Figure 4 and Table 3<br>Global Change of pin 4 name from VDD_A to DEC_1V2<br>Section 6 Application Notes – revised and expanded information on programming examples                             | 5 <sup>th</sup> May 2022       |

This is Provisional Information; changes and additions may be made to this specification. Parameters marked TBD or left blank will be included in later issues. Items that are highlighted or greyed out should be ignored. These will be clarified in later issues of this document.

## 2 Block Diagram

### 2.1 CMX655D

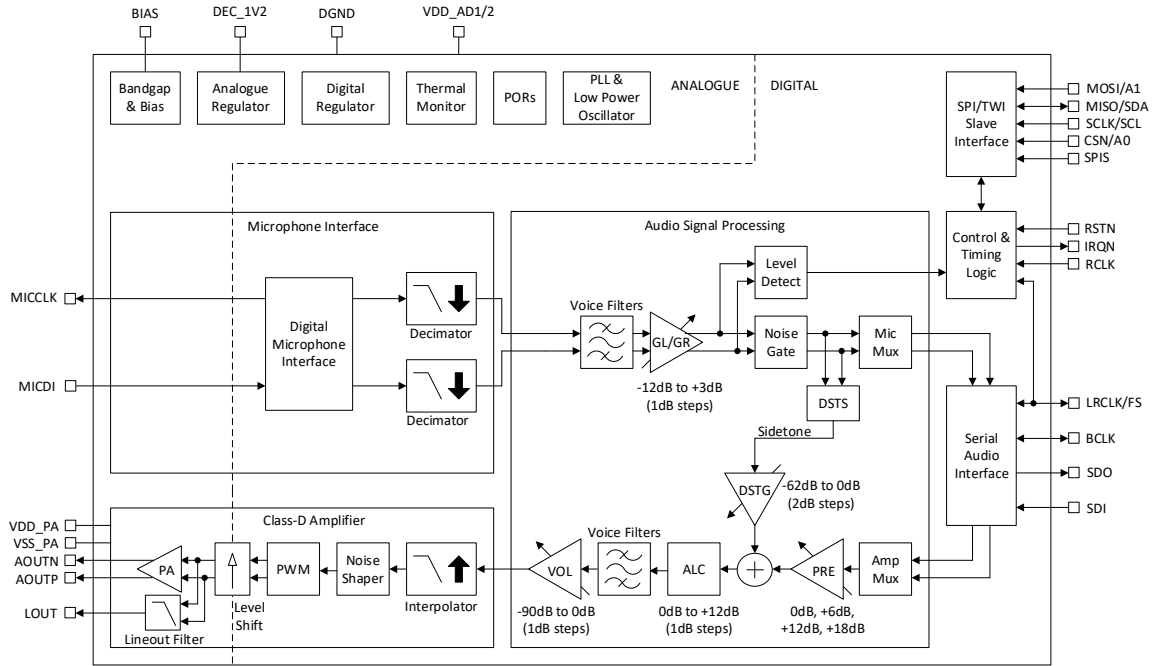


Figure 2 CMX655D Block Diagram

### 3 Pin List

#### 3.1 CMX655D

**Table 1 CMX655D Pin List by Number**

| Number | Name     | Type | Function   |
|--------|----------|------|--|
| 1      | AOUTN    | AO   | Class-D Amplifier Output Negative                                |
| 2      | VDD_PA   | VDD  | Class-D Supply: 2.7-3.6V (high current)                          |
| 3      | LOUT     | AO   | Lineout  |
| 4      | DEC_1V2  | VDD  | 1.2V Regulator Decouple  |
| 5      | BIAS     | AO   | Bias Current Resistor  |
| 6      | NC1      | NC   | No Connection  |
| 7      | VDD_AD1  | VDD  | Analogue/Digital Supply 2.7-3.6V (1.75-3.6V if VDD_PA unused)    |
| 8      | VDD_AD2  | VDD  | Analogue/Digital Supply 2.7-3.6V (1.75-3.6V if VDD_PA unused)    |
| 9      | RSTN     | DI   | Active Low Reset   |
| 10     | MICCLK   | DO   | Digital Microphone Clock Output                                  |
| 11     | MICDI    | DI   | Digital Microphone Data Input                                    |
| 12     | RCLK     | DI   | PLL Reference/Main clock   |
| 13     | LRCLK/FS | DIO  | Left-Right Clock/PCM Frame Sync/PLL Reference                    |
| 14     | SDI      | DI   | Serial Audio Data Input  |
| 15     | SDO      | DO   | Serial Audio Data Output   |
| 16     | BCLK     | DIO  | Serial Audio Data Clock  |
| 17     | SPIS     | DI   | SPI Select: 0=TWI, 1=SPI   |
| 18     | IRQN     | DO   | Active Low Interrupt. Open-drain – connect to VDD_AD via pull up |
| 19     | SCLK/SCL | DI   | SPI SCLK/TWI SCL   |
| 20     | MISO/SDA | DIO  | SPI MISO/TWI SDA   |
| 21     | MOSI/A1  | DI   | SPI MOSI/TWI A1  |
| 22     | CSN/A0   | DI   | SPI CSN/TWI A0   |
| 23     | AOUTP    | AO   | Class-D Amplifier Output Positive                                |
| 24     | VSS_PA   | GND  | Class-D Ground   |
| PADDLE | DGND     | GND  | Digital and Analogue Ground                                      |

AIO Analogue Input / Output  
 AI Analogue Input  
 AO Analogue Output  
 NC Not Connected  
 GND Ground

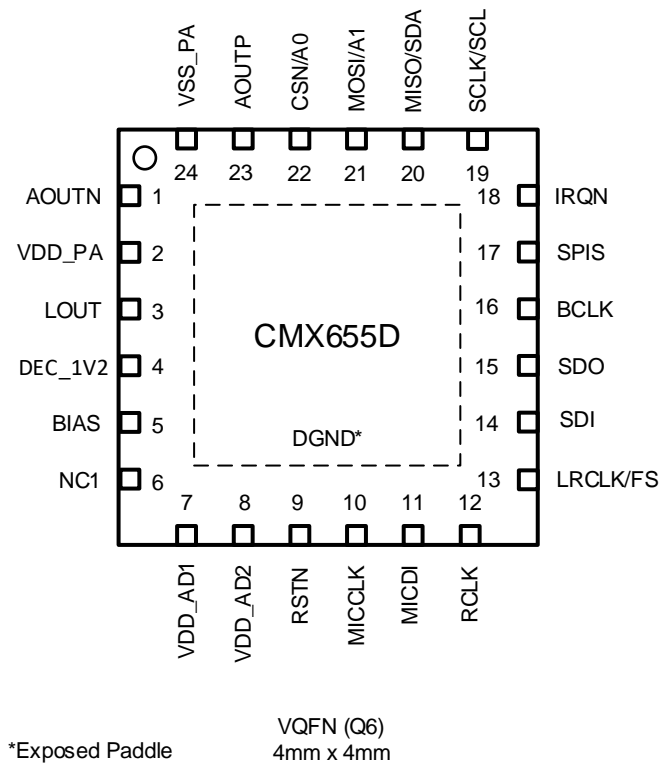
DIO Digital Input / Output  
 DI Digital Input  
 DO Digital Output  
 VDD Supply

Table 2 CMX655D Pin List by Group

| Number                              | Name     | Type | Function   |
|-------------------------------------|----------|------|--|
| <b>Power</b>                        |          |      |  |
| 2                                   | VDD_PA   | VDD  | Class-D Supply: 2.7-3.6V (high current)                          |
| 4                                   | DEC_1V2  | VDD  | 1.2V Analogue Regulator Decouple                                 |
| 7                                   | VDD_AD1  | VDD  | Analogue/Digital Supply 2.7-3.6V (1.75-3.6V if VDD_PA unused)    |
| 8                                   | VDD_AD2  | VDD  | Analogue/Digital Supply 2.7-3.6V (1.75-3.6V if VDD_PA unused)    |
| 24                                  | VSS_PA   | GND  | Class-D Ground   |
| PADDLE                              | DGND     | GND  | Digital and Analogue Ground                                      |
| <b>Reference and Bias</b>           |          |      |  |
| 5                                   | BIAS     | AI   | Bias Current Resistor  |
| <b>Class-D Amplifier Outputs</b>    |          |      |  |
| 1                                   | AOUTN    | AO   | Class-D Amplifier Output Negative                                |
| 3                                   | LOUT     | AO   | Lineout  |
| 23                                  | AOUTP    | AO   | Class-D Amplifier Output Positive                                |
| <b>Microphone Interface</b>         |          |      |  |
| 10                                  | MICCLK   | DO   | Digital Microphone Clock Output                                  |
| 11                                  | MICDI    | DI   | Digital Microphone Data Input                                    |
| <b>General System &amp; Control</b> |          |      |  |
| 9                                   | RSTN     | DI   | Active Low Reset   |
| 12                                  | RCLK     | DI   | PLL Reference/Main clock   |
| 18                                  | IRQN     | DO   | Active Low Interrupt. Open-drain - connect to VDD_AD via pull-up |
| <b>Control Interface</b>            |          |      |  |
| 17                                  | SPIS     | DI   | SPI Select: 0=TWI, 1=SPI   |
| 19                                  | SCLK/SCL | DI   | SPI SCLK/TWI SCL   |
| 20                                  | MISO/SDA | DIO  | SPI MISO/TWI SDA   |
| 21                                  | MOSI/A1  | DI   | SPI MOSI/TWI A1  |
| 22                                  | CSN/A0   | DI   | SPI CSN/TWI A0   |
| <b>Serial Audio Interface</b>       |          |      |  |
| 13                                  | LRCLK/FS | DIO  | Left-Right Clock/PCM Frame Sync/PLL Reference                    |
| 14                                  | SDI      | DI   | Serial Audio Data Input  |
| 15                                  | SDO      | DO   | Serial Audio Data Output   |
| 16                                  | BCLK     | DIO  | Serial Audio Data Clock  |

AIO Analogue Input / Output  
 AI Analogue Input  
 AO Analogue Output  
 NC Not Connected  
 GND Ground

DIO Digital Input / Output  
 DI Digital Input  
 DO Digital Output  
 VDD Supply



**Figure 3 CMX655D Pin Arrangement**



## 4 External Components

### 4.1 CMX655D

#### 4.1.1 Power Supply and Pin Decoupling

The CMX655D has two supply pins, VDD\_AD and VDD\_PA, which should be connected to the same nominal supply voltage of 3V. If the Class-D amplifier is not required, VDD\_PA may be disconnected from the supply and connected to ground allowing VDD\_AD to operate from a minimum supply voltage of 1.75V.

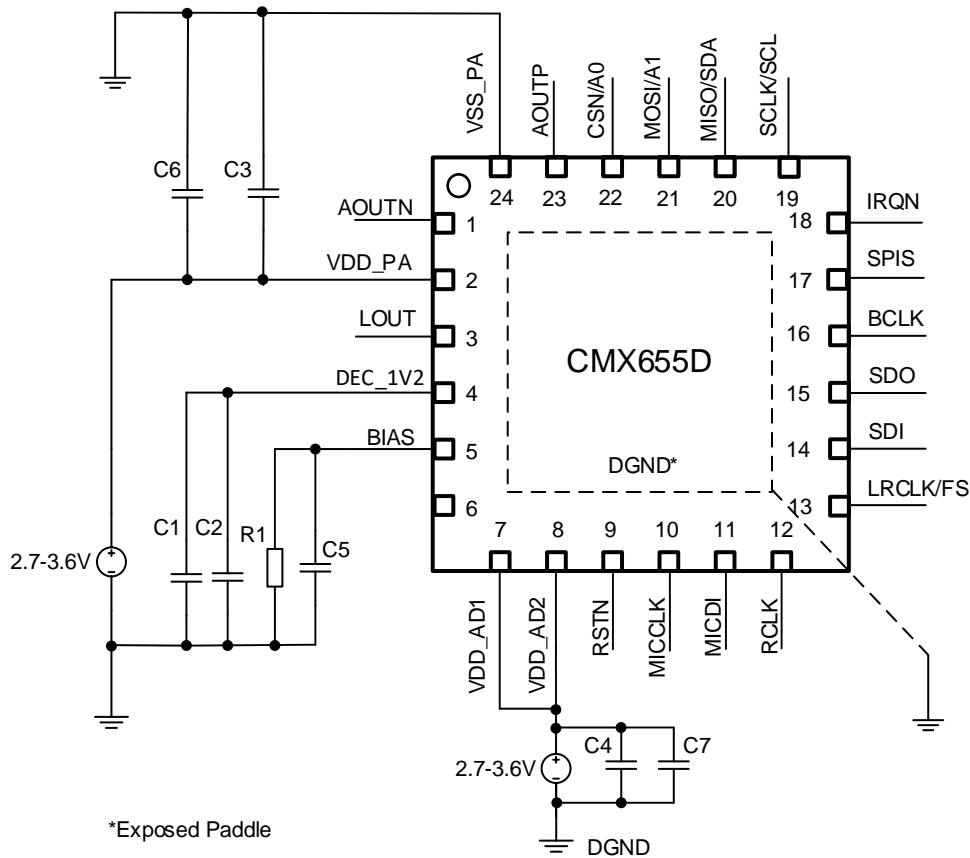


Figure 4 CMX655D Power Supply and Pin Decoupling

Table 3 CMX655D Component Values

|    |       |
|----|-------|
| C1 | 100nF |
| C2 | 100pF |
| C3 | 10nF  |
| C4 | 10nF  |
| C5 | 10pF  |
| C6 | 10µF  |
| C7 | 10µF  |
| R1 | 60kΩ  |

Capacitors ±5%, Resistors ±1%

4.1.2 SPI

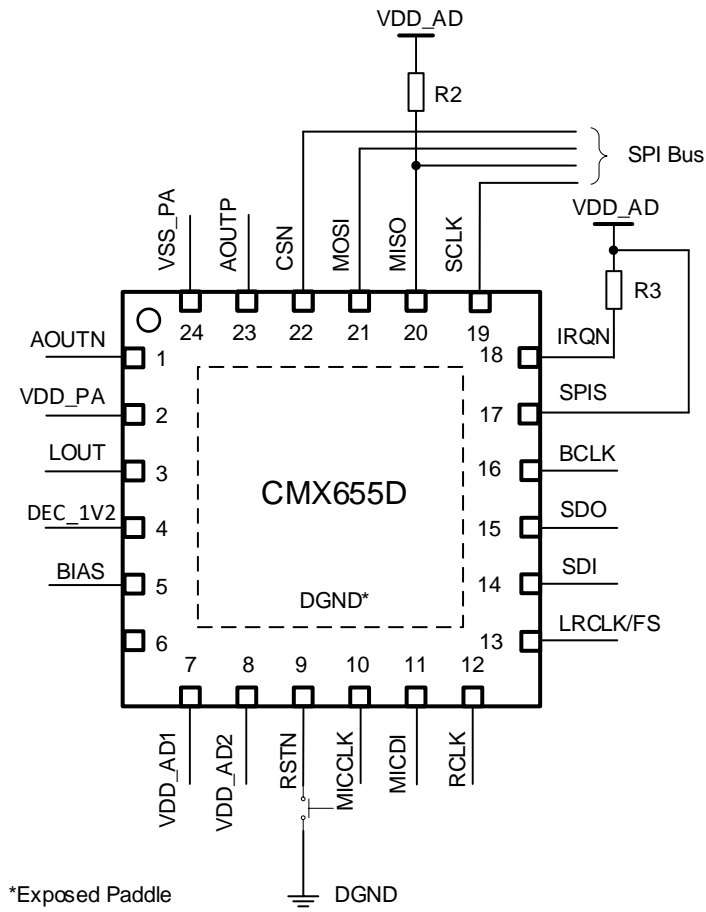


Figure 5 CMX655D SPI Connections

Table 4 CMX655D SPI Component Value

|    |      |
|----|------|
| R2 | 10kΩ |
| R3 | 47kΩ |

Resistors ±1%

4.1.3 TWI

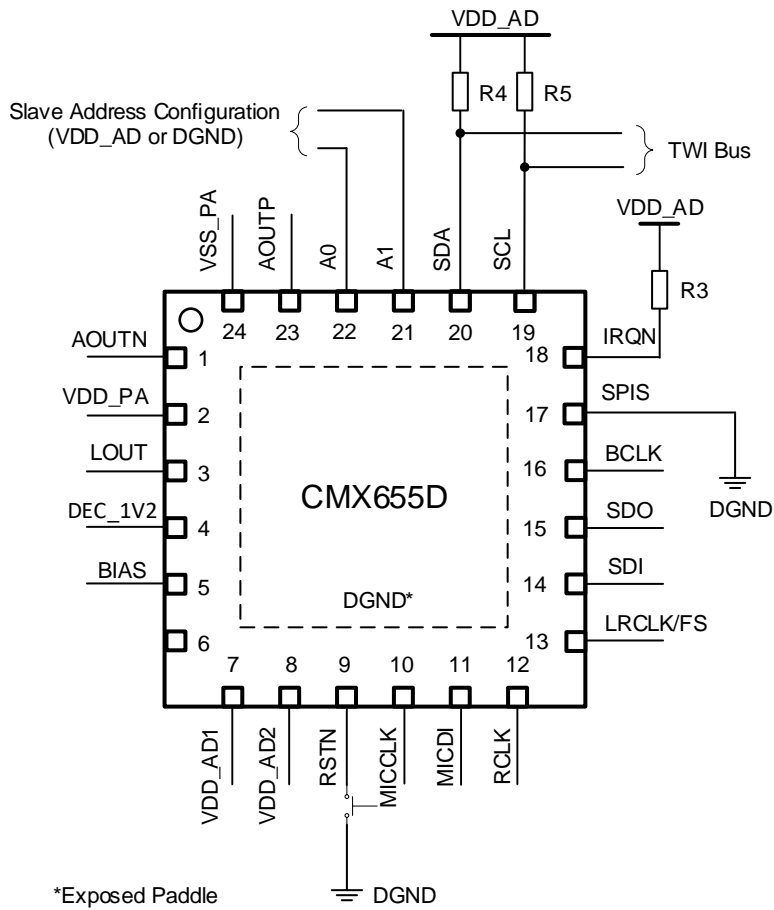


Figure 6 CMX655D TWI Connections

Table 5 CMX655D TWI Component Values

|    |                |
|----|----------------|
| R3 | 47kΩ           |
| R4 | R <sub>p</sub> |
| R5 | R <sub>p</sub> |

Resistors ±1%

The value of R<sub>p</sub> is given in Table 13.

4.1.4 Speaker and Microphone

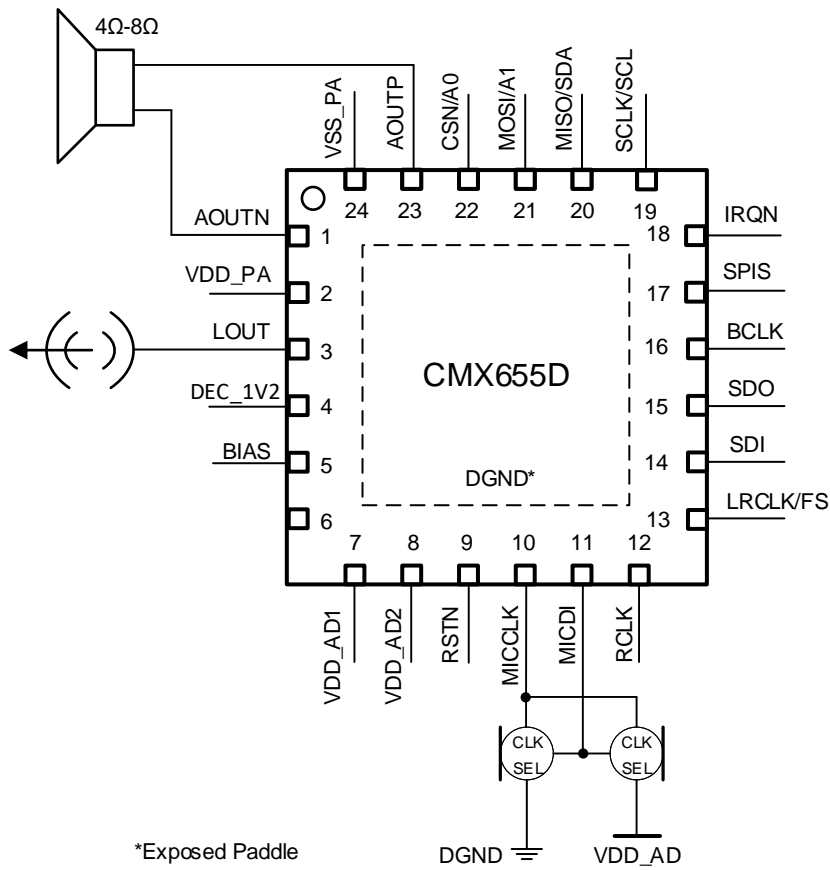


Figure 7 CMX655D Speaker and Microphone Connections

## 5 General Description

### 5.1 Power Management

#### 5.1.1 External Supplies

The external unregulated supplies required by the CMX655D are VDD\_AD connected to the VDD\_AD pin and VDD\_PA connected to the VDD\_PA1 pin. The exposed paddle on the underside of the package is the digital and analogue ground.

VDD\_PA solely powers the Class-D power-amplifier output stage that drives the AOUTN and AOUTP pins. VDD\_AD powers the Class-D lineout output stage and the remaining analogue and digital circuits.

When the CMX655D Class-D power-amplifier is in use, the VDD\_PA and VDD\_AD supplies must operate at the same voltage between 2.7-3.6V. If the CMX655D Class-D power-amplifier is not required, the VDD\_PA supply may be connected to analogue ground and the VDD\_AD supply may operate between 2.7V-3.6V. If both the Class-D power-amplifier and lineout are not required, the VDD\_AD supply may operate between 1.75-3.6V, see Table 10 below.

**Table 6 External Supply Voltages**

| Class-D PA In Use | Class-D Lineout In Use | VDD_AD       | VDD_PA         |
|-------------------|------------------------|--------------|----------------|
| Yes               | Yes                    | 2.7 to 3.6V  | Same as VDD_AD |
| Yes               | No                     | 2.7 to 3.6V  | Same as VDD_AD |
| No                | Yes                    | 2.7 to 3.6V  | Not Required   |
| No                | No                     | 1.75 to 3.6V | Not Required   |

#### 5.1.2 Regulated Supplies

The CMX655D contains integrated voltage regulators powered from VDD\_AD that generate 1.2V regulated supply rails for the digital (VDD\_D) and analogue (VDD\_A) circuits in the device. The regulated analogue supply rail is externally decoupled via the DEC\_1V2 pin.

### 5.2 Device Reset

The CMX655D device reset is activated by the integrated power-on-reset (POR) generator on the VDD\_D voltage domain and the active low reset pin RSTN. While reset is in progress, the CMX655D SPI/TWI interface must remain in its idle state, without being accessed.

#### 5.2.1 Power-On-Reset

The CMX655D POR voltage thresholds are listed in Table 7.

**Table 7 Supply and POR Threshold Voltages**

| Supply | Nominal Voltage (V) | POR Voltage (V) |
|--------|---------------------|-----------------|
| VDD_A  | 1.2                 | 0.93            |
| VDD_D  | 1.2                 | 0.93            |

The reset signal produced by each POR generator is asserted within 1 $\mu$ s of the power-on-reset threshold voltage being exceeded.

Once the VDD\_D power-on-reset threshold voltage has been exceeded the device will be released from reset and this will occur within 10 $\mu$ s of the VDD\_AD supply reaching 1.75V.

#### 5.2.2 Reset Pin

The CMX655D may be reset while the device remains powered-up by externally driving the RSTN pin low to DGND. A reset duration of 1 $\mu$ s minimum is recommended.

### 5.3 Main Clock

The control registers and functions associated with the audio signal processing, the Class-D amplifier, the microphone channels and the Serial Audio Interface require the main clock to be active before they may be modified.

Note: After device reset, the first main clock source selected must always be the low power oscillator (LPOSC), and the main clock must then be started. The main clock source configuration may be subsequently changed.

#### 5.3.1 Clock Frequency

The CMX655D is designed to operate with a main internal clock frequency of 24.576MHz.

#### 5.3.2 Clock Generation

From reset, the device is in its lowest power state with the main clock (CLK) internally deactivated. The main clock must first be configured and activated before attempting to access and control other device functions however, device registers can be accessed via the SPI/TWI Control Interface while the main clock is not active.

The required main clock frequency of 24.576MHz may be directly applied to the CMX655D via the RCLK pin. If the exact main clock frequency cannot be supplied by the external system, the CMX655D integer-N PLL may be configured and enabled to generate the required main clock from either RCLK or the serial audio interface sample rate clock LRCLK/FS external signals, as shown in Figure 8.

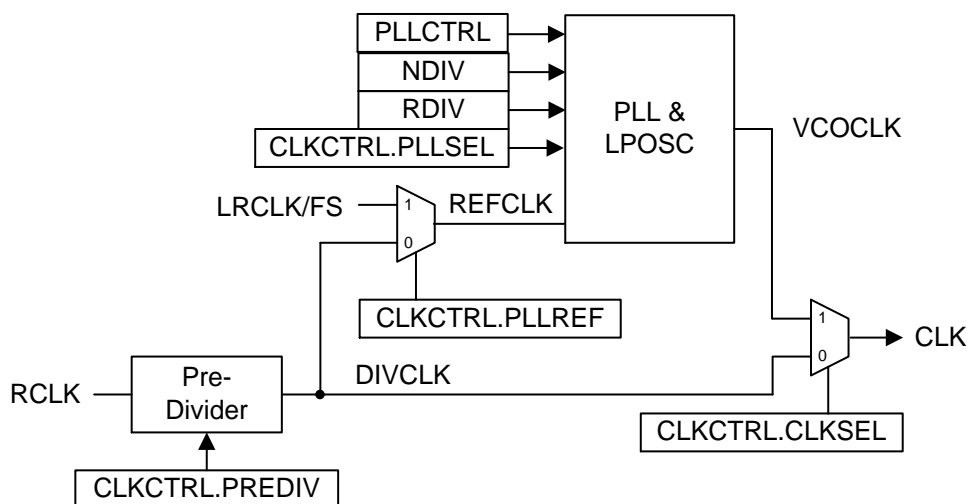


Figure 8 Main Clock Generation

The LRCLK/FS signal may only be selected as the PLL reference clock if the CMX655D Serial Audio Interface operates as a slave. In this operating mode, LRCLK/FS is generated by the external master and is an input to the CMX655D and the RCLK input is unused and may be tied low or high as appropriate.

If the CMX655D Serial Audio Interface (SAI) operates as the slave, the CMX655D main clock must be synchronous to LRCLK/FS to avoid audio sample slippage due to clock drift between the CMX655D internal sample rate (derived from the main clock) and the external sample rate indicated on LRCLK/FS and generated by the SAI master. If LRCLK/FS is not used as the PLL reference clock to derive the main clock when the CMX655D SAI operates as the slave, then the external system should ensure that LRCLK/FS is synchronous with respect to RCLK.

The **CLKCTRL**, **RDIVHI**, **RDIVLO**, **NDIVHI**, **NDIVLO** and **PLLCTRL** register settings should first be configured prior to activating the main clock.

Prior to activating the main clock, the IRQN pin may be configured to indicate when the main clock has successfully started by setting the CLKRDY bit in the **ISM** register. The main clock is activated by writing \$01 (Clock Start command) to the **COMMAND** register. The CLKRDY bit in the **ISR** register is set when the clock goes ready. This bit is cleared on reading the **ISR** register. It is not possible to modify the **CLKCTRL** register after the main clock is activated. The **RDIVHI**, **RDIVLO**, **NDIVHI**, **NDIVLO** and **PLLCTRL** registers should not be modified if the main clock is active and generated by the PLL.

To return the device to its lowest power state, the **SYCTRL** register should first be cleared after which the main clock may be deactivated by writing \$00 (Clock Stop command) to the **COMMAND** register. The main clock will stop within four main clock cycles after the Clock Stop command has been transferred. If the main clock is derived from the PLL clock at the time the main clock is deactivated, the external clock source used for the PLL reference (i.e. RCLK or LRCLK/FS) must only be disabled at least four REFCLK cycles after the Clock Stop command has been transferred.

After the main clock has stopped, the Microphone Interface, Class-D Amplifier, Audio Signal Processing and Serial Audio Interface are held in reset until the main clock is next restarted.

The CMX655D low-power oscillator, LPOSC, generates a nominal 24.576MHz clock. The LPOSC allows the CMX655D to perform record level detection without an external clock supplied to the device. When the LPOSC is used as the main clock source, the SAI and Class-D amplifier must be disabled because the LPOSC frequency is too low and not sufficiently accurate to support these functions. If the detected microphone audio level exceeds a programmable threshold an associated interrupt may be indicated on the IRQN pin. The interrupt may be used to wake-up a sleeping external controller that subsequently re-enables the external clock source (i.e. RCLK or LRCLK/FS) and places the CMX655D back into a fully featured operating mode that makes use of the active external clock to derive the main clock.

### 5.3.3 PLL

The basic integer-N PLL block diagram is shown in Figure 9.

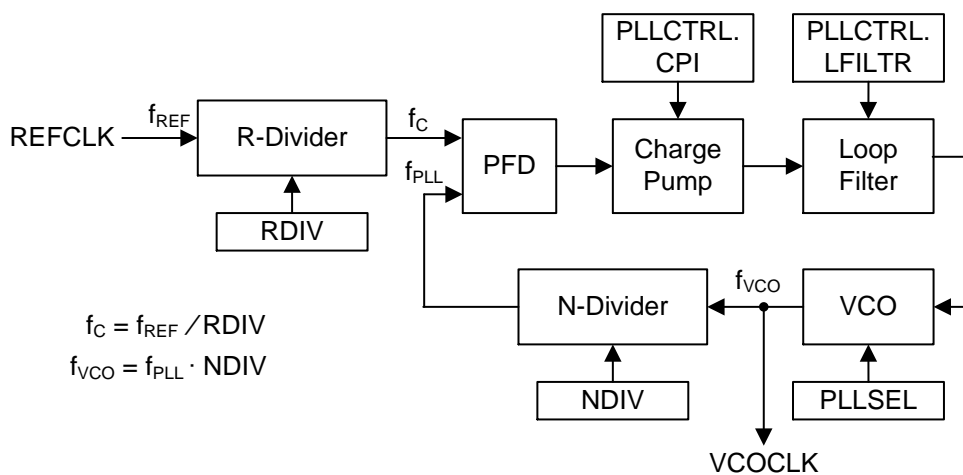


Figure 9 Integer-N PLL

The REFCLK is taken from RCLK (i.e. a common crystal oscillator frequency) or the sample rate clock input on LRCLK/FS (i.e. 8/16/32/48kHz). The frequency range of REFCLK is 8kHz–20MHz. The PLL is fully integrated within the CMX655D so there is no requirement for any external loop filter components. The PLL loop filter is shown in Figure 10.

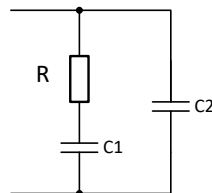


Figure 10 PLL Loop Filter

C1 is 54pF, C2 is 5.4pF and R is adjustable via bits 7-4 of the register PLLCTRL.

### 5.3.4 Low Power Oscillator

The LPOSC generates a nominal 24.576MHz clock. When the LPOSC is selected as the main clock source, the VCO operates as an open-loop ring oscillator and the remaining PLL components are disabled. The LPOSC supports record level detection without the requirement of an external clock source to be applied to the CMX655D.

### 5.3.5 Clock Control Registers

#### 5.3.5.1 CLKCTRL (\$03)

Clock Control (R/W)

Reset Value: \$00

| 7 | 6  | 5 | 4      | 3      | 2      | 1      | 0 |
|---|----|---|--------|--------|--------|--------|---|
| 0 | SR |   | PLLREF | PLLSEL | CLKSEL | PREDIV |   |

**SR**                    **Sample Rate ( $f_s$ )**

|   |        |
|---|--------|
| 0 | 8ksps  |
| 1 | 16ksps |
| 2 | 32ksps |
| 3 | 48ksps |

**PLLREF**            **PLL Reference Clock Source**

|   |  |
|---|--|
| 0 | DIVCLK   |
| 1 | LRCLK/FS - requires CMX655D Serial Audio Interface to operate as a slave |

**PLLSEL**            **PLL Select**

|   |                       |
|---|-----------------------|
| 0 | Open-loop VCO (LPOSC) |
| 1 | Closed-loop PLL       |

**CLKSEL**            **Clock Selection**

|   |               |
|---|---------------|
| 0 | Select DIVCLK |
| 1 | Select VCOCLK |

**PREDIV**            **Pre-divider**

|     |             |
|-----|-------------|
| 0   | Divide by 1 |
| 1   | Divide by 2 |
| 2-3 | Divide by 4 |

#### 5.3.5.2 RDIVHI (\$04)

R-Divider High Byte (R/W)

Reset Value: \$00

| 7 | 6 | 5 | 4          | 3 | 2 | 1 | 0 |
|---|---|---|------------|---|---|---|---|
| 0 |   |   | RDIV[12:8] |   |   |   |   |

#### 5.3.5.3 RDIVLO (\$05)

R-Divider Low Byte (R/W)

Reset Value: \$00

| 7         | 6 | 5 | 4 | 3 | 2 | 1 | 0 |
|-----------|---|---|---|---|---|---|---|
| RDIV[7:0] |   |   |   |   |   |   |   |

**RDIV[12:0]**        **Divide Value**

|        |                  |
|--------|------------------|
| 0      | Divide by 8192   |
| 1-8191 | Divide by 1-8191 |



**5.3.5.4 NDIVHI (\$06)**

N-Divider High Byte (R/W)

Reset Value: \$00

|   |   |   |   |            |   |   |   |
|---|---|---|---|------------|---|---|---|
| 7 | 6 | 5 | 4 | 3          | 2 | 1 | 0 |
| 0 |   |   |   | NDIV[12:8] |   |   |   |

**5.3.5.5 NDIVLO (\$07)**

N-Divider Low Byte (R/W)

Reset Value: \$00

|           |   |   |   |   |   |   |   |
|-----------|---|---|---|---|---|---|---|
| 7         | 6 | 5 | 4 | 3 | 2 | 1 | 0 |
| NDIV[7:0] |   |   |   |   |   |   |   |

**NDIV[12:0] Divide Value**

0 Divide by 8192

1-8191 Divide by 1-8191

**5.3.5.6 PLLCTRL (\$08)**

PLL Control (R/W)

Reset Value: \$00

|   |   |   |   |     |   |   |   |
|---|---|---|---|-----|---|---|---|
| 7 | 6 | 5 | 4 | 3   | 2 | 1 | 0 |
| R |   |   |   | CPI |   |   |   |

**R Loop Filter Resistor ( $\Omega$ )**

|    |                 |
|----|-----------------|
| 0  | 17.5 k $\Omega$ |
| 1  | 25 k $\Omega$   |
| 2  | 35 k $\Omega$   |
| 3  | 50 k $\Omega$   |
| 4  | 70 k $\Omega$   |
| 5  | 100 k $\Omega$  |
| 6  | 140 k $\Omega$  |
| 7  | 200 k $\Omega$  |
| 8  | 280 k $\Omega$  |
| 9  | 400 k $\Omega$  |
| 10 | 560 k $\Omega$  |
| 11 | 800 k $\Omega$  |
| 12 | 1.12 M $\Omega$ |
| 13 | 1.6 M $\Omega$  |
| 14 | 2.24 M $\Omega$ |
| 15 | 3.2 M $\Omega$  |

**CPI Charge Pump Current Gain ( $\mu\text{A}/\text{cycle}$ )**

|    |       |
|----|-------|
| 0  | 0.0   |
| 1  | 0.05  |
| 2  | 0.075 |
| 3  | 0.1   |
| 4  | 0.15  |
| 5  | 0.2   |
| 6  | 0.3   |
| 7  | 0.4   |
| 8  | 0.55  |
| 9  | 0.8   |
| 10 | 1.15  |
| 11 | 1.6   |
| 12 | 2.25  |
| 13 | 3.2   |
| 14 | 4.45  |
| 15 | 6.2   |

## 5.4 Microphone Interface

### 5.4.1 Digital Microphone Interface

The CMX655D drives the MICCLK pin which connects to the external microphone(s) clock input and receives a PDM bit-stream on MICDI from the microphone(s) data output. Digital MEMS microphones are configured to output the PDM bit-stream for either positive or negative clock edge operation, with the data-line going high-impedance for the inactive clock edge. This allows two microphones to share a common clock and data line when configured to operate on opposite clock edges to support 2-channel audio. The CMX655D samples left channel data on the falling edge of MICCLK and right channel data on the rising edge of MICCLK as shown in Figure 11.

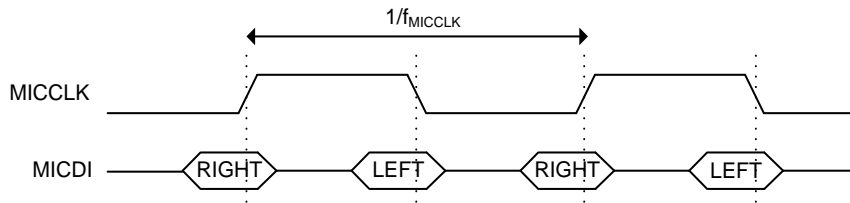


Figure 11 CMX655D Digital Microphone Interface

The CMX655D drives MICCLK with a 50% duty cycle at a frequency of  $f_{MICCLK}$ . If the sample rate is 48ksps, then  $f_{MICCLK} = 3.072\text{MHz}$ . For the remaining sample rates of 8/16/32ksps,  $f_{MICCLK} = 2.048\text{MHz}$ .

## 5.5 Class-D Amplifier

### 5.5.1 Audio Outputs

The CMX655D Class-D amplifier provides differential power outputs (AOUTP, AOUTN) for driving a speaker with 4Ω-8Ω impedance and a single-ended lineout (LOUT) for driving a minimum load impedance of 18kΩ in parallel with 120pF.

Class-D Power Amplifier specifications are provided for 4 ohm and 8 ohm loads. The amplifier also operates with other load impedances ranging from below 4 ohms to infinite ohms (open circuit). Performance with load impedance other than 4 ohms and 8 ohms may be different than is specified for 4 ohm and 8 ohm loads. Generally, as load impedance decreases, amplifier output power increases and power efficiency decreases. Maximum speaker driver current limiting and optionally enabled thermal protection can limit the minimum load impedance and output level for load impedance less than 4 ohms.

### 5.5.2 Overload Current Protection

The CMX655D differential power outputs of the Class-D amplifier are protected against overload current conditions with an automatic shut-off protection circuit. Overload current protection is enabled when the **SYCTRL** register PAMP bit is set to 1. The overload current condition may be configured to signal an interrupt via the IRQN pin as described in section 5.9.

### 5.5.3 Thermal Protection

The CMX655D includes an integrated thermal detection circuit which automatically powers-down the Class-D amplifier differential power outputs when the device temperature reaches a critical level. Thermal protection is enabled when the **SYCTRL** register PAMP bit is set to 1. The thermal protection event may be configured to signal an interrupt via the IRQN pin as described in section 5.9.

### 5.5.4 Clipping Detection

A clipping detection circuit within the CMX655D Class-D amplifier monitors if the differential power output stage is in saturation and distorting the playback signal. The clipping detection circuit is enabled when the **SYCTRL** register PAMP bit is set to 1. The clipping detection interrupt generation is enabled using the **ISE** register. The clipping detection circuit may be configured to signal an interrupt via the IRQN pin as described in section 5.9.

## 5.6 Audio Signal Processing

### 5.6.1 Record Level Control

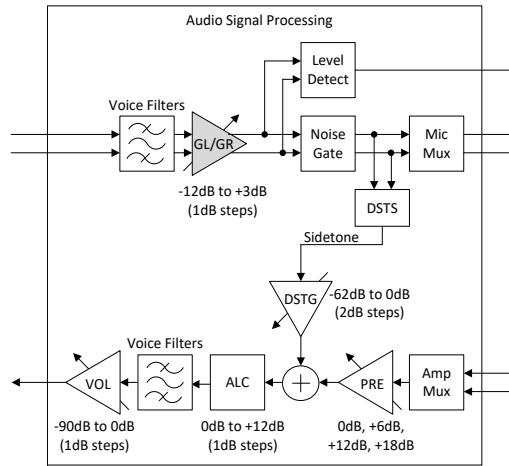


Figure 12 Audio signal processing block diagram with gain level block highlighted

The record levels of the left and right channels are controlled by the gain settings in the **LEVEL** register. The gain applied to each channel may be independently set from -12dB to +3dB in 1dB steps.

#### 5.6.1.1 Record Level Control Register

##### LEVEL (\$0F)

Record Level (R/W)

Reset Value: \$00

|    |   |   |   |    |   |   |   |
|----|---|---|---|----|---|---|---|
| 7  | 6 | 5 | 4 | 3  | 2 | 1 | 0 |
| GL |   |   |   | GR |   |   |   |

**GL**      **Gain Left channel**  
0-15      -12dB to +3dB (+1dB steps)

**GR**      **Gain Right channel**  
0-15      -12dB to +3dB (+1dB steps)

#### 5.6.2 Noise Gate

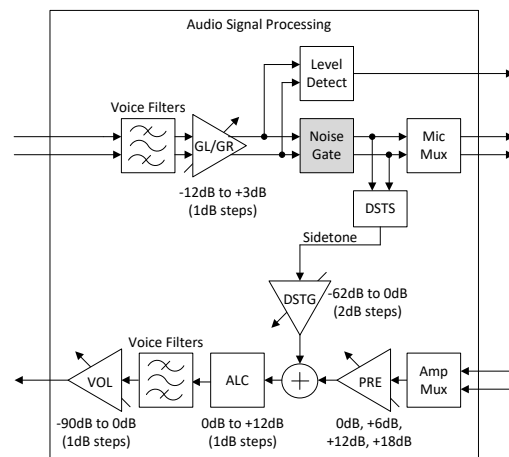


Figure 13 Audio signal processing block diagram with Noise Gate block highlighted

The noise gate function is designed to attenuate low-level record signals that fall below a pre-programmed noise threshold. Noise gating is implemented using downward expansion such that the output signal level is attenuated in proportion to the degree in which the peak input signal level is below the expansion threshold. Downward expansion results in a soft noise gating response due to the gradual attenuation applied to the input signal. The input-to-output signal level ratio below the threshold may be programmed as 1:2, 1:3 or 1:4. The noise gate is controlled by the **NGCTRL** register. The ideal expansion attenuation  $A_{EXP}$  (dB) when the input signal (dBFS) is below the expansion threshold (dBFS) for a given an expansion ratio of 1:E is:

$$A_{EXP} = (E-1) * (\text{Threshold} - \text{Input})$$

However, it should be noted that  $A_{EXP}$  is only controlled using 1dB of resolution and that the maximum attenuation applied by the noise gate is limited to 31dB. Figure 14 shows the ideal noise gate response for these ratios with the threshold set to -50dBFS. The 1:1 ratio is effective when the noise gate is disabled.

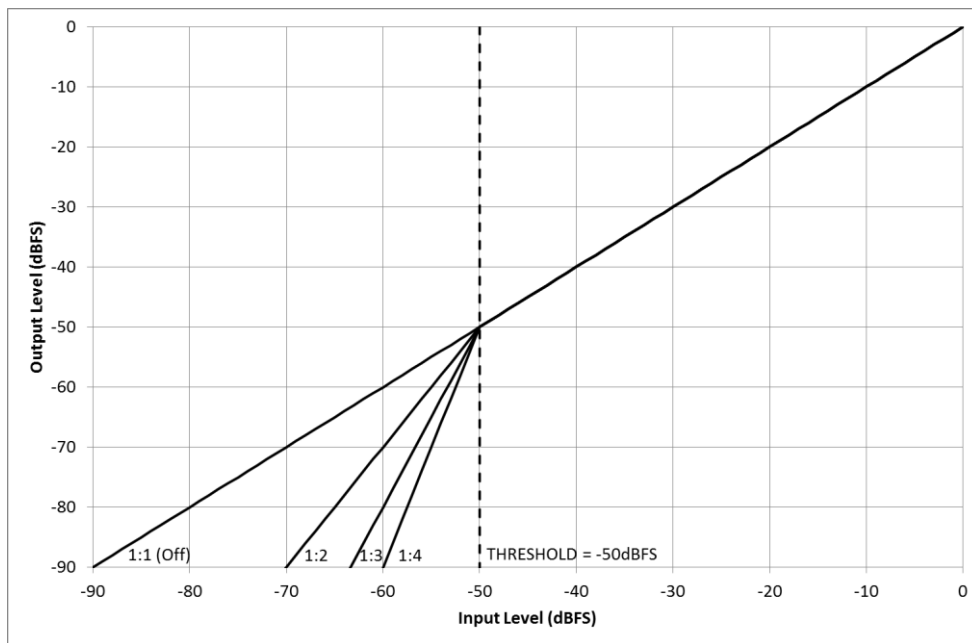


Figure 14 Noise Gate Response

When enabled, the noise gate function operates independently on the left and right record channel. The noise gate response time is programmed using the **NGTIME** register. The release time determines how long it would take for the noise gate to apply 12dB of downwards expansion when the input signal falls below the threshold. The attack time determines how long it would take the noise gate to remove 12dB of downwards expansion once the signal rises back above the threshold. The release and attack times therefore determine the rate at which expansion is applied and removed. The attenuation applied to the left and right record channel may be read from **NGLSTAT** and **NGRSTAT** registers respectively.

5.6.2.1 Noise Gate Registers

**NGCTRL (\$1C)**

Noise Gate Control (R/W)

Reset Value: \$00

|    |       |   |        |   |   |   |   |
|----|-------|---|--------|---|---|---|---|
| 7  | 6     | 5 | 4      | 3 | 2 | 1 | 0 |
| EN | RATIO |   | THRESH |   |   |   |   |

- EN**            **Enable**
- 0                Noise Gate disabled (1:1 ratio)
- 1                Noise Gate enabled

|              |   |
|--------------|---|
| <b>RATIO</b> | <b>Input-to-output signal level ratio below Threshold when Noise Gate enabled</b> |
| 0            | 1:2   |
| 1            | 1:3   |
| 2-3          | 1:4   |

|               |                                 |
|---------------|---------------------------------|
| <b>THRESH</b> | <b>Threshold</b>                |
| 0-31          | -63dBFS to -32dBFS (+1dB steps) |

**NGTIME (\$1D)**

Noise Gate Time (R/W)

Reset Value: \$00

| 7 | 6      | 5 | 4 | 3 | 2       | 1 | 0 |
|---|--------|---|---|---|---------|---|---|
| 0 | ATTACK |   |   | 0 | RELEASE |   |   |

|               |                         |
|---------------|-------------------------|
| <b>ATTACK</b> | <b>Attack Time (ms)</b> |
| 0             | 1.5                     |
| 1             | 3                       |
| 2             | 4.5                     |
| 3             | 6                       |
| 4             | 12                      |
| 5             | 24                      |
| 6             | 48                      |
| 7             | 96                      |

|                |                         |
|----------------|-------------------------|
| <b>RELEASE</b> | <b>Release Time (s)</b> |
| 0              | 0.06                    |
| 1              | 0.12                    |
| 2              | 0.24                    |
| 3              | 0.48                    |
| 4              | 0.96                    |
| 5              | 1.92                    |
| 6              | 3.84                    |
| 7              | 7.68                    |

**NGLSTAT (\$1E)**

Noise Gate Left Channel Status (R)

Reset Value: \$00

| 7 | 6 | 5 | 4     | 3 | 2 | 1 | 0 |
|---|---|---|-------|---|---|---|---|
| 0 |   |   | ATTEN |   |   |   |   |

|              |                           |
|--------------|---------------------------|
| <b>ATTEN</b> | <b>Attenuation</b>        |
| 0-31         | 0dB to +31dB (+1dB steps) |

**NGRSTAT (\$1F)**

Noise Gate Right Channel Status (R)

Reset Value: \$00

| 7 | 6 | 5 | 4     | 3 | 2 | 1 | 0 |
|---|---|---|-------|---|---|---|---|
| 0 |   |   | ATTEN |   |   |   |   |

|              |                           |
|--------------|---------------------------|
| <b>ATTEN</b> | <b>Attenuation</b>        |
| 0-31         | 0dB to +31dB (+1dB steps) |

5.6.3 Record Level Detection

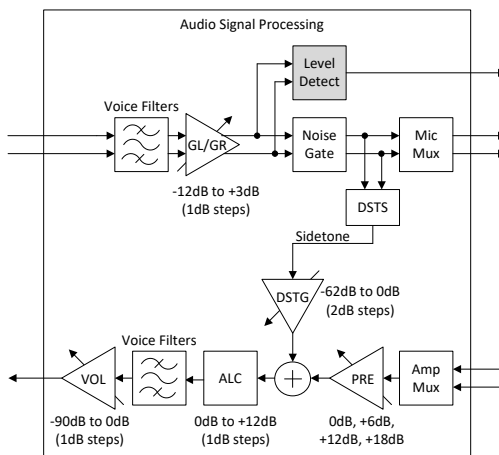


Figure 15 Audio signal processing block diagram with Level Detect block highlighted

The record level detection function continuously monitors the record signal level and can be configured to trigger an interrupt when the record signal level exceeds a pre-programmed detection threshold. This feature is useful in low-power listening mode applications, such as a voice activated switch (VOX), where the CMX655D record level interrupt signal is used to wake-up a sleeping external host. The record level detection function interrupt enable bits are set in the **ISM** register and the record level detection thresholds for the left and right channels are independently set by the **LDCTRL** and **RDCTRL** registers respectively.

Each of left and right level detectors operates in a one-shot manner; a detector is automatically disabled when triggered and cannot be enabled again until its corresponding MICL or MICR bit in the **ISR** is cleared by a read of the **ISR** register.

5.6.3.1 Record Level Detection Registers

**LDCTRL (\$0D)**

Left Channel Detection Control (R/W)  
Reset Value: \$00

|     |   |         |   |   |   |   |   |
|-----|---|---------|---|---|---|---|---|
| 7   | 6 | 5       | 4 | 3 | 2 | 1 | 0 |
| LEN |   | LTHRESH |   |   |   |   |   |

**LEN**                      **Left Channel Detection Enable**  
 0                          Disable left channel interrupt detection.  
 1                          Enable left channel interrupt detection.  
 LEN is automatically cleared to 0 if the **ISR** MICL bit is set to 1. The LEN bit is equivalent to and its state is always the same as that of the MICL **ISE** register bit.

**LTHRESH**              **Left Channel Detection Threshold**  
 0-89                      -90dBFS to -1dBFS (+1dB steps)  
 90-127                    -1dBFS

**RDCTRL (\$0E)**

Right Channel Detection Control (R/W)  
Reset Value: \$00

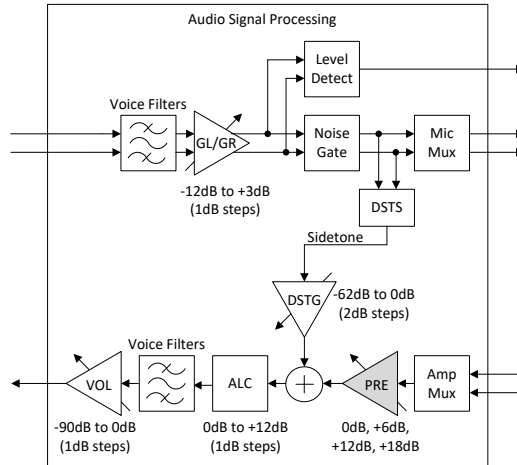
|     |   |         |   |   |   |   |   |
|-----|---|---------|---|---|---|---|---|
| 7   | 6 | 5       | 4 | 3 | 2 | 1 | 0 |
| REN |   | RTHRESH |   |   |   |   |   |

**REN**                      **Right Channel Detection Enable**  
 0                          Disable right channel interrupt detection.  
 1                          Enable right channel interrupt detection.  
 REN is automatically cleared to 0 if the **ISR** MICR bit is set to 1. The REN bit is equivalent to and its

state is always the same as that of the MICR ISE register bit.

|                |  |
|----------------|--|
| <b>RTHRESH</b> | <b>Right Channel Detection Threshold</b> |
| 0-89           | -90dBFS to -1dBFS (+1dB steps)           |
| 90-127         | -1dBFS                                   |

**5.6.4 Playback Preamplifier Gain**



**Figure 16 Audio signal processing block diagram with preamp block highlighted**

The **PREAMP** register sets the playback preamplifier gain to 1/2/4/8 (approximately 0/6/12/18dB).

**5.6.4.1 Playback Preamplifier Gain Register**

**PREAMP (\$29)**  
 Playback Preamp Gain (R/W)  
 Reset Value: \$00

|   |   |   |   |   |   |   |     |
|---|---|---|---|---|---|---|-----|
| 7 | 6 | 5 | 4 | 3 | 2 | 1 | 0   |
| 0 |   |   |   |   |   |   | PRE |

|            |                           |
|------------|---------------------------|
| <b>PRE</b> | <b>Pre-amplifier Gain</b> |
| 0          | 1 (0dB)                   |
| 1          | 2 (6dB)                   |
| 2          | 4 (12dB)                  |
| 3          | 8 (18dB)                  |

5.6.5 Playback Volume Control

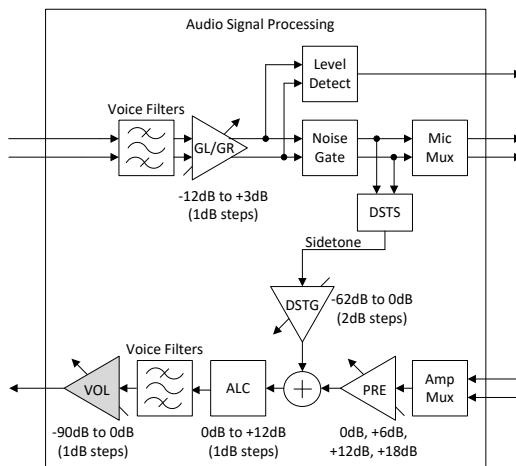


Figure 17 Audio signal processing block diagram with the volume block highlighted

The **VOLUME** register sets the playback amplifier gain between 0dB and -90dB in 1dB steps.

5.6.5.1 Playback Volume Register

**VOLUME (\$2A)**

Playback Volume (R/W)

Reset Value: \$00

|        |   |     |   |   |   |   |   |
|--------|---|-----|---|---|---|---|---|
| 7      | 6 | 5   | 4 | 3 | 2 | 1 | 0 |
| SMOOTH |   | VOL |   |   |   |   |   |

**SMOOTH**

**Volume Smoothing**

- 0 Volume smoothing disabled - the VOL setting is applied immediately
- 1 Volume smoothing enabled - the VOL setting is applied gradually using intermediate gain steps near zero-crossings or after a 5ms timeout if no zero-crossing is detected

**VOL**

**Volume Gain Setting**

- 0 Mute
- 1-91 -90dB to 0dB (+1dB steps)
- 92-127 0dB

The generation of the VOL interrupt status bit in the **ISR** bit register is enabled by setting the VOL interrupt enable bit in the **ISE** register. The VOL **ISR** bit indicates that volume gain adjustment has completed, which occurs 32 sample periods after the applied volume gain equals the volume gain setting. To avoid the immediate generation of a VOL interrupt, the VOL **ISE** bit should only be set following a change in the volume gain setting.

To reduce click-and-pop artefacts, it is recommended to mute the volume and wait for volume gain adjustment completion before clearing the PAMP bit in the **SYSCTRL** register when disabling the Class-D power amplifier.



5.6.6 Automatic Level Control

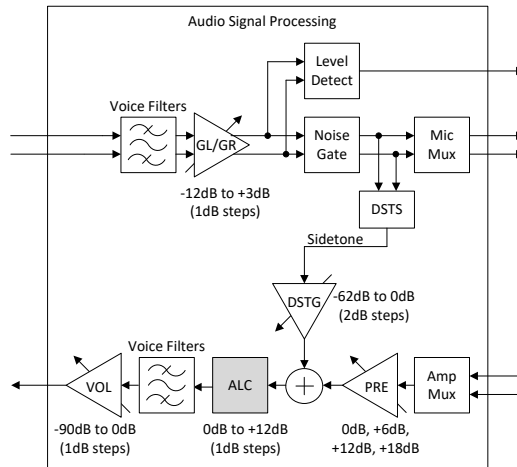


Figure 18 Audio signal processing block diagram with ALC block highlighted

The ALC function is designed to enhance low-level playback signals by reducing the dynamic range of the output signal with respect to the input signal. The ALC is implemented using downward compression such that the output signal level is attenuated in proportion to the degree in which the peak input signal level is above the compression threshold. The ALC is controlled using the **ALCCTRL** register where the input-to-output signal level ratio above the compression threshold may be programmed as 1.5:1, 2:1, 4:1 or ∞:1. The ideal compression attenuation  $A_{COM}$  (dB) when the input signal (dBFS) is above the compression threshold (dBFS) for a given a compression ratio of C:1 is:

$$A_{COM} = (C-1) * (Input - Threshold) / C$$

However, it should be noted that  $A_{COM}$  is only controlled using 1dB of resolution. Figure 19 shows the ideal ALC response for these ratios with the threshold set to -30dBFS.

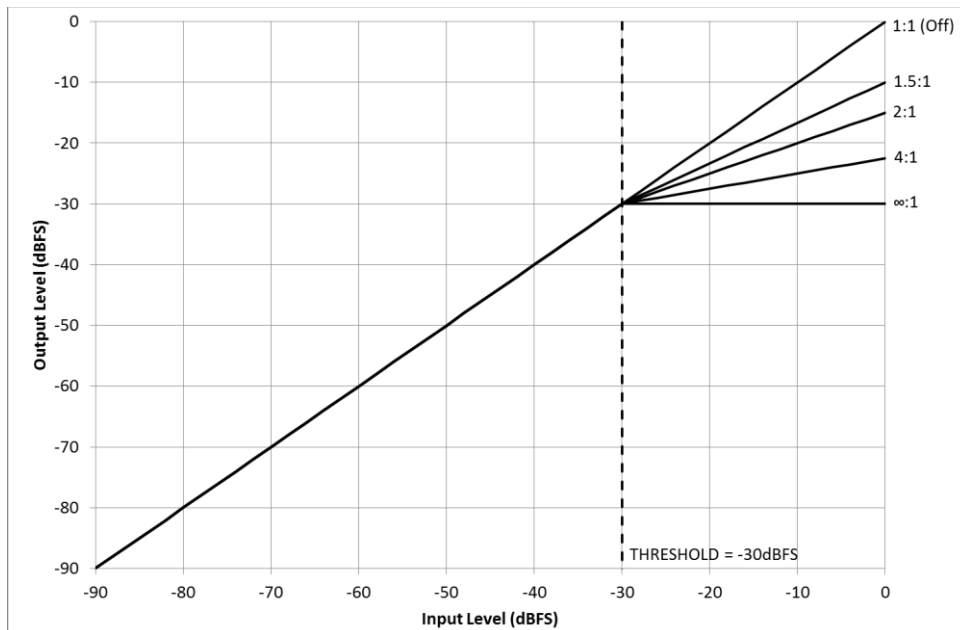


Figure 19 ALC Response

The ALC response time is programmed using the **ALCTIME** register. The attack time determines how long it would take the ALC to apply 12dB of downwards compression when the input signal rises above the threshold. The release time determines how long it would take the ALC to remove 12dB of downwards compression once the signal falls back below the threshold. The attack and release times therefore determine the rate at which compression is applied and removed.

To make-up for lost gain due to the downwards compression, up to 12dB of make-up gain is selectable using the **ALCGAIN** register. The make-up gain is applied regardless of whether the ALC is enabled. The compression attenuation applied by the ALC excluding the make-up gain may be read from the **ALCSTAT** register.

### 5.6.6.1 ALC Registers

#### ALCCTRL (\$2B)

ALC Control (R/W)

Reset Value: \$00

| 7  | 6     | 5 | 4      | 3 | 2 | 1 | 0 |
|----|-------|---|--------|---|---|---|---|
| EN | RATIO |   | THRESH |   |   |   |   |

#### EN Enable

0 ALC disabled (1:1 ratio)

1 ALC enabled

#### RATIO Input-to-output signal level ratio above Threshold when ALC enabled

0 1.5:1

1 2:1

2 4:1

3  $\infty$ :1

#### THRESH Threshold

0-31 -31dBFS to 0dBFS (+1dB steps)

#### ALCTIME (\$2C)

ALC Time (R/W)

Reset Value: \$00

| 7 | 6      | 5 | 4 | 3 | 2       | 1 | 0 |
|---|--------|---|---|---|---------|---|---|
| 0 | ATTACK |   |   | 0 | RELEASE |   |   |

#### ATTACK Attack Time (ms)

0 1.5

1 3

2 4.5

3 6

4 12

5 24

6 48

7 96

#### RELEASE Release Time (s)

0 0.06

1 0.12

2 0.24

3 0.48

4 0.96

5 1.92

6 3.84

7 7.68

**ALCGAIN (\$2D)**

ALC Make-up Gain (R/W)

Reset Value: \$00

|   |   |   |   |      |   |   |   |
|---|---|---|---|------|---|---|---|
| 7 | 6 | 5 | 4 | 3    | 2 | 1 | 0 |
| 0 |   |   |   | GAIN |   |   |   |

|             |                       |
|-------------|-----------------------|
| <b>GAIN</b> | <b>Make-up Gain</b>   |
| 0-12        | 0dB-12dB (+1dB steps) |
| 13-15       | 12dB                  |

**ALCSTAT (\$2E)**

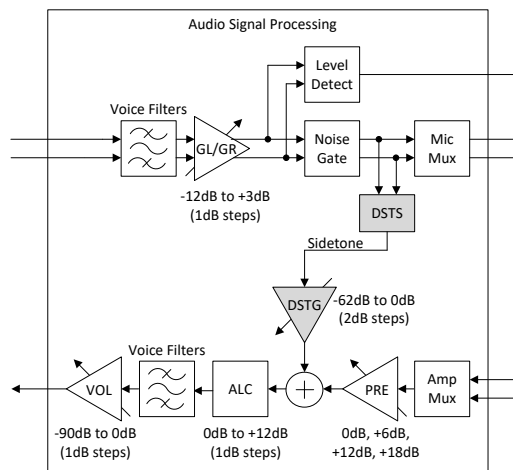
ALC Status (R)

Reset Value: \$00

|   |   |   |   |       |   |   |   |
|---|---|---|---|-------|---|---|---|
| 7 | 6 | 5 | 4 | 3     | 2 | 1 | 0 |
| 0 |   |   |   | ATTEN |   |   |   |

|              |                           |
|--------------|---------------------------|
| <b>ATTEN</b> | <b>ALC Attenuation</b>    |
| 0-31         | 0dB to +31dB (+1dB steps) |

**5.6.7 Digital Sidetone**



**Figure 20 Audio signal processing block diagram with the Digital Side Tone path and block highlighted**

Digital sidetone feeds a proportion of the microphone signal back into the playback signal path to provide audible feedback to the speaking user. The sidetone level and input source are controlled by the DST register which provides programmable signal attenuation of -62dB to 0dB in +2dB steps.

**5.6.7.1 Digital Sidetone Register**

**DST (\$2F)**

Digital Sidetone Control (R/W)

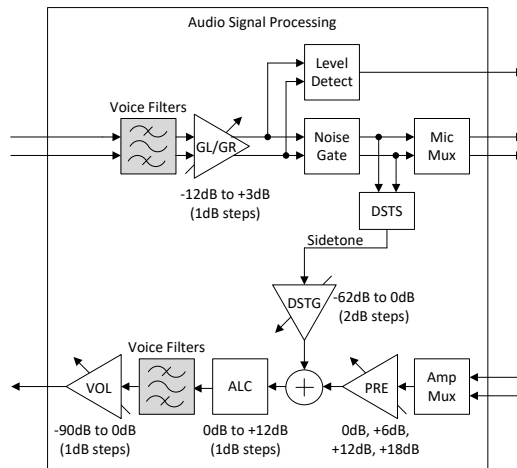
Reset Value: \$00

|    |      |   |      |   |   |   |   |
|----|------|---|------|---|---|---|---|
| 7  | 6    | 5 | 4    | 3 | 2 | 1 | 0 |
| EN | DSTS |   | DSTG |   |   |   |   |

|           |                                |
|-----------|--------------------------------|
| <b>EN</b> | <b>Digital Sidetone Enable</b> |
| 0         | Sidetone disabled (muted)      |
| 1         | Sidetone enabled               |

- DSTS**      **Digital Sidetone Source**
- 0            Left microphone signal
- 1            Right microphone signal
- 2-3         Mean of left and right microphone signals
  
- DSTG**      **Digital Sidetone Gain**
- 0 to 31     -62dB to 0dB (+2dB steps)

**5.6.8 Voice Filters**

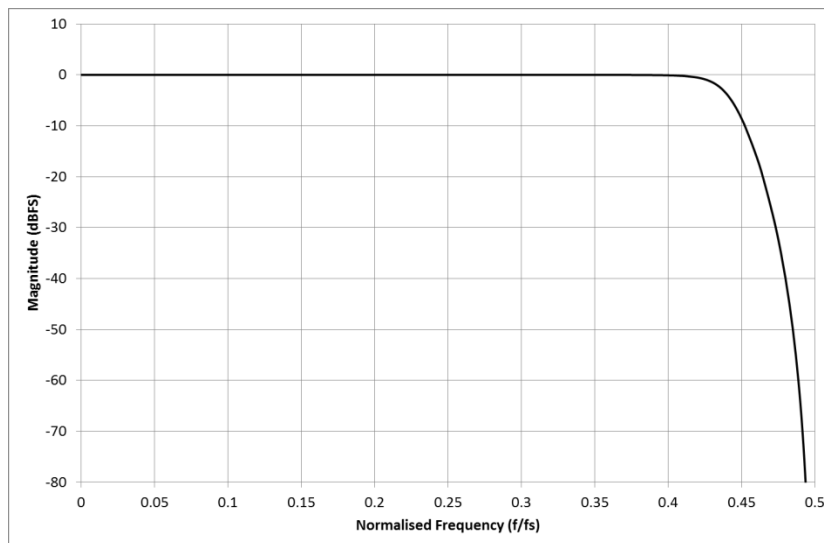


**Figure 21 Audio signal processing block diagram with Voice Filter blocks highlighted**

The voice filters provide narrow audio band filtering and may be optionally enabled as required.

**5.6.8.1 Low Pass Filter**

The low pass IIR filter has a 4<sup>th</sup>-order Butterworth response with a passband -3dB point of  $0.4375 \times f_s$  (i.e. 3500/7000/14000/21000Hz @ 8/16/32/48kpsps). The low pass filter for the record and playback channels is enabled by the LPFEN bit in the **RVF** and **PVF** registers respectively. The frequency response of the low pass filter is shown in Figure 22.



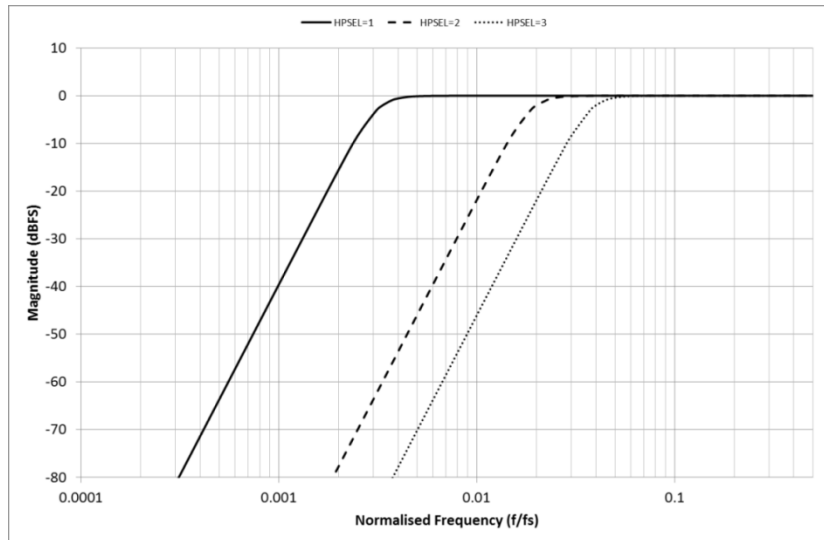
**Figure 22 Low Pass Filter Frequency Response**

**5.6.8.2 DC Blocking Filter**

The DC blocking filter provides 90dB of DC attenuation. The DC blocking filter for the record and playback channels is enabled by the DCBEN bit in the **RVF** and **PVF** registers respectively.

**5.6.8.3 High Pass Filter**

The high pass IIR filter has a 4<sup>th</sup>-order Butterworth response with three selectable -3dB points to accommodate different applications and may be optionally disabled. The high pass filter for the record and playback channels is controlled by the HPSEL bits in the **RVF** and **PVF** registers respectively. The frequency response of the high pass filters are shown in Figure 23.



**Figure 23 High Pass Filter Frequency Response**

**5.6.8.4 Voice Filters Registers**

**RVF (\$0C)**

Record Voice Filters (R/W)

Reset Value: \$00

|   |   |   |       |       |       |   |   |
|---|---|---|-------|-------|-------|---|---|
| 7 | 6 | 5 | 4     | 3     | 2     | 1 | 0 |
| 0 |   |   | LPFEN | DCBEN | HPSEL |   |   |

**LPFEN**      **Record Low Pass Filter Enable**  
 0              Low pass filter disabled  
 1              Low pass filter enabled

**DCBEN**      **Record DC Blocking Filter Enable**  
 0              DC blocking filter disabled  
 1              DC blocking filter enabled

**HPSEL**      **Record High Pass Filter Select**  
 0              High pass filter disabled  
 1              High pass filter with a -3dB point of  $0.003125 \times f_s$  (e.g. -3dB point of 50Hz @ 16ksps)  
 2              High pass filter with a -3dB point of  $0.01875 \times f_s$  (e.g. -3dB point of 300Hz @ 16ksps)  
 3              High pass filter with a -3dB point of  $0.0375 \times f_s$  (e.g. -3dB point of 300Hz @ 8ksps)

**PVF (\$28)**

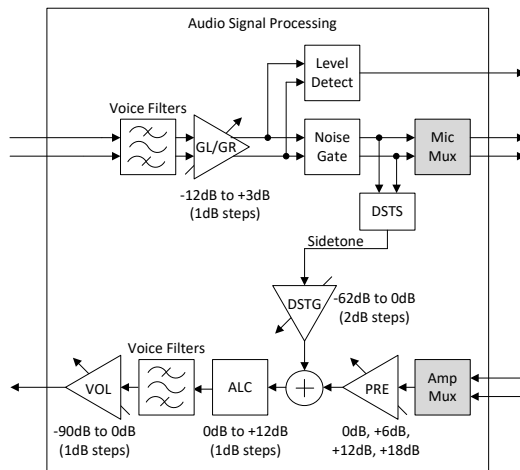
Playback Voice Filters (R/W)

Reset Value: \$00

|   |   |   |       |       |       |   |   |
|---|---|---|-------|-------|-------|---|---|
| 7 | 6 | 5 | 4     | 3     | 2     | 1 | 0 |
| 0 |   |   | LPFEN | DCBEN | HPSEL |   |   |

|              |  |
|--------------|--|
| <b>LPFEN</b> | <b>Playback Low Pass Filter Enable</b>   |
| 0            | Low pass filter disabled   |
| 1            | Low pass filter enabled  |
| <b>DCBEN</b> | <b>Playback DC Blocking Filter Enable</b>  |
| 0            | DC blocking filter disabled  |
| 1            | DC blocking filter enabled   |
| <b>HPSEL</b> | <b>Playback High Pass Filter Select</b>  |
| 0            | High pass filter disabled  |
| 1            | High pass filter with a -3dB point of $0.003125 \times f_s$ (e.g. -3dB point of 50Hz @ 16ksps) |
| 2            | High pass filter with a -3dB point of $0.01875 \times f_s$ (e.g. -3dB point of 300Hz @ 16ksps) |
| 3            | High pass filter with a -3dB point of $0.0375 \times f_s$ (e.g. -3dB point of 300Hz @ 8ksps)   |

**5.6.9 Channel Multiplexing**



**Figure 24 Audio signal processing block diagram with Mic Mux and Amp Mux block highlighted**

The left and right microphone output channels may be interchanged or duplicated by appropriately setting the MIC control bits in the **SAIMUX** register defined in section 5.8.5. The interchange and duplication of channels requires both microphone channels to be enabled.

The mono amplifier input channel may be selected from the left input or the right input or the mean of the left and right inputs by appropriately setting the AMP control bits in the **SAIMUX** register.

**5.6.10 Click-and-Pop Reduction**

The CMX655D provides a soft mute function that generates low-level background noise when the playback volume is muted which potentially reduces audible click-and-pop artefacts.

**5.6.10.1 Click-and-Pop Reduction Register**

**CPR (\$30)**

Click-and-Pop Reduction (R/W)

Reset Value: \$00

|          |          |          |          |          |          |          |          |
|----------|----------|----------|----------|----------|----------|----------|----------|
| <b>7</b> | <b>6</b> | <b>5</b> | <b>4</b> | <b>3</b> | <b>2</b> | <b>1</b> | <b>0</b> |
|          |          |          |          |          |          |          | 0        |
|          |          |          |          |          |          |          | SOFTM    |

|              |                     |
|--------------|---------------------|
| <b>SOFTM</b> | <b>Soft Mute</b>    |
| 0            | Soft mute disabled. |
| 1            | Soft mute enabled.  |

### 5.7 Control Interface

The CMX655D is configured and controlled via the Control Interface. The interface communicates as a SPI Slave when the external SPIS pin is tied high to VDD\_AD or as a TWI Slave when the external SPIS pin is tied low to DGND. These interfaces allow communication with standard MCUs and DSPs and are commonly used by existing audio codecs.

#### 5.7.1 SPI Slave

The CMX655D SPI Slave responds to activity on the SPI-bus when the chip-select pin CSN is driven low. Input data on MOSI is clocked in by the CMX655D SPI Slave on the rising edge of SCLK. Output data on MISO is clocked out by the CMX655D SPI Slave on the falling edge of SCLK when transferring read data.

The CMX655D SPI Slave only drives MISO when transferring read data from a valid device address. This feature allows the CMX655D SPI pin connections to be potentially shared with other CML C-BUS slave devices. An external pull-up resistor to VDD\_AD (or pull-down resistor to DGND) must be connected to MISO to prevent the node from floating when not driven by the CMX655D SPI Slave or any other connected device. The CMX655D SPI Slave is insensitive to the polarity of SCLK at the start and end of each transfer and is compatible with SPI masters operating in SPI Mode 0 (CPOL=0, CPHA=0) or SPI Mode 3 (CPOL=1, CPHA=1).

The CMX655D communicates over the SPI interface using a transfer width of 16-bits. Figure 25 shows the SPI transfer protocol for performing a single-byte write to the CMX655D .

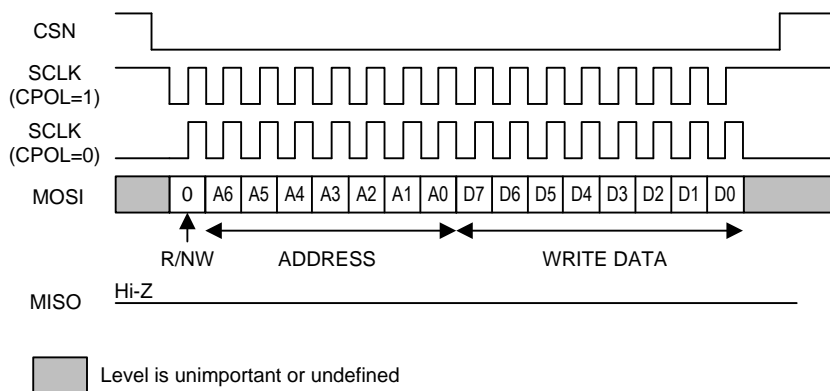


Figure 25 SPI Write Transfer

The first bit on MOSI is the Read/NotWrite bit (R/NW) and this is set to 0 to indicate a write transfer and the following 7-bits (A6 to A0) indicate the register address to be written (MSB first). The remaining 8-bits on MOSI (D7 to D0) indicate the data to be written (MSB first).

Figure 26 shows the SPI transfer protocol for performing a single-byte read from the CMX655D.

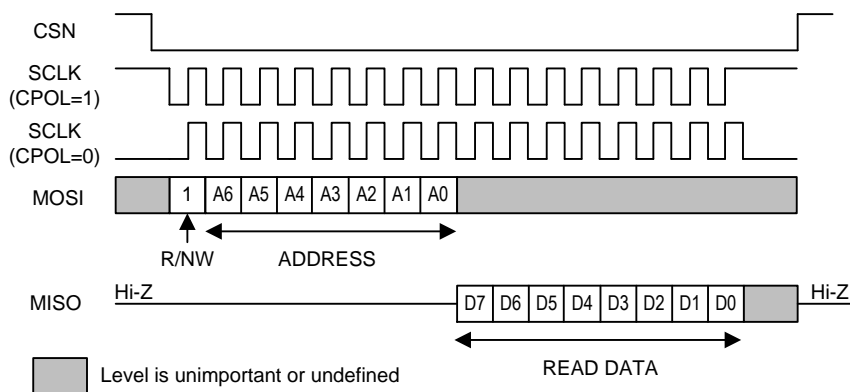


Figure 26 SPI Read Transfer

The R/NW bit is set to 1 to indicate a read transfer and the following 7-bits (A6 to A0) indicate the register address to be read (MSB first). The CMX655D drives the data read from the address onto MISO (D7 to D0) in the following 8 SCLK cycles (MSB first). The CMX655D will only drive read data onto MISO if the register address is defined or reserved by the CMX655D. Read transfers from unallocated register addresses will result in MISO remaining not driven by the CMX655D.

The CMX655D automatically increments the register address internally after each data byte is transferred. SPI masters capable of transfer widths in excess of 16-bits may take advantage of this feature to perform consecutive write (or read) address accesses within the same transfer with reduced addressing overhead as shown in Figure 27 and Figure 28.

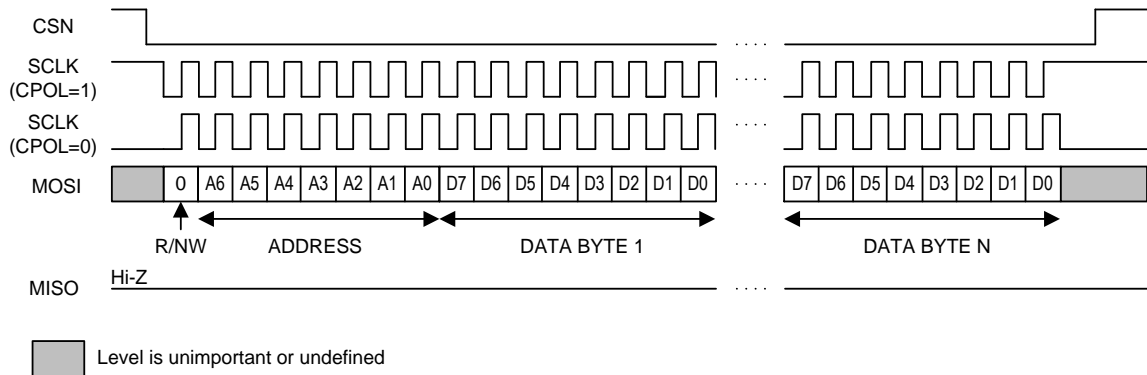


Figure 27 SPI N-Byte Write Transfer

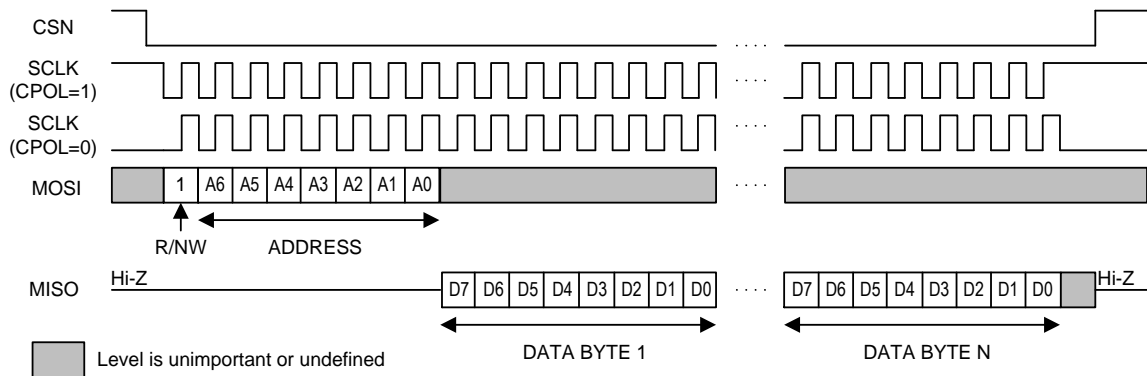


Figure 28 SPI N-Byte Read Transfer

It should be noted that the internal address saturates at \$7F and does not auto-increment to wrap back around to \$00.

5.7.2 TWI Slave

The CMX655D TWI Slave is compatible with the I<sup>2</sup>C-bus Standard-mode (100 kHz) and Fast-mode (400 kHz) operating speeds. The TWI clock line is the SCL pin and the TWI data line is the SDA pin. External pull-up resistors to VDD\_AD must be connected to the SDA and SCL pins.

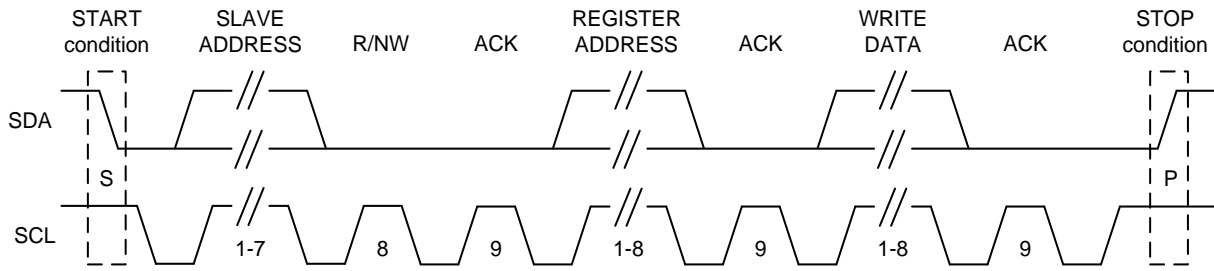
The value of the A1 and A0 pins are address bits 1 and 0 respectively of the 7-bit Slave Address. The remaining upper 5-bits of the 7-bit Slave Address are hard-coded in the device as 10101 binary. The CMX655D TWI Slave may be configured to respond to the following 7-bit Slave Addresses listed in Table 8.

Table 8 CMX655D Slave Addresses

| 7-bit Slave Address | A1 | A0 |
|---------------------|----|----|
| 1010100 (0x54)      | 0  | 0  |
| 1010101 (0x55)      | 0  | 1  |
| 1010110 (0x56)      | 1  | 0  |
| 1010111 (0x57)      | 1  | 1  |



Figure 29 shows the TWI transfer protocol for performing a single-byte write to the CMX655.



**Figure 29 TWI Write Transfer**

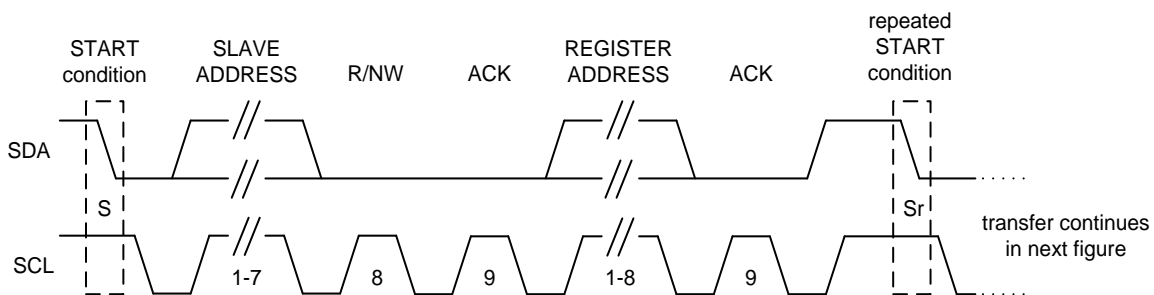
The TWI master initiates each transaction by generating a START (S) condition defined as a high-to-low transition on SDA while SCL is high. The TWI master terminates each transfer by generating a STOP condition (P) defined as a low-to-high transition on SDA while SCL is high. Each byte placed on the TWI-bus is transferred MSB first and is followed by an Acknowledge bit. The CMX655D TWI Slave does not perform clock-stretching and will not drive the SCL line.

Following the START condition, the first byte the master places on the TWI-bus consists of the 7-bit Slave Address of the target slave followed by the R/NW bit indicating a read (R/NW=1) or write (R/NW=0) transaction. The target slave will respond with an acknowledgement by driving the Acknowledgement bit (ACK) low. For writes (R/NW=0), the TWI master will drive the following data bytes (REGISTER ADDRESS) and the TWI slave will drive the Acknowledgement bit. For reads (R/NW=1), the TWI slave will drive the following data bytes (READ DATA) and the TWI master will drive the Acknowledgement bit.

If the 7-bit Slave Address does not match the CMX655D Slave Address (see Table 8) then the CMX655D TWI Slave will remain idle until a new START condition is generated. If the 7-bit Slave Address matches the CMX655D Slave Address then the CMX655D TWI Slave will respond by driving the SDA line low to indicate an Acknowledgement (ACK).

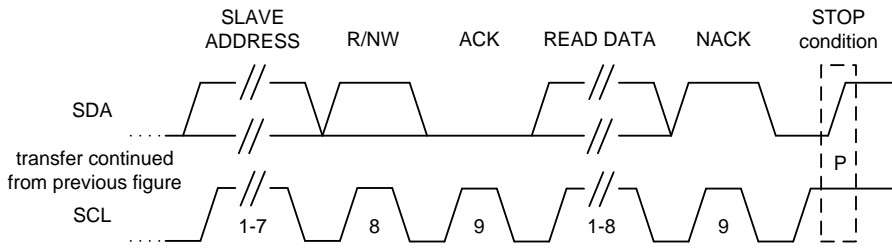
For a write transaction (R/NW=0), the next byte placed on the TWI-bus by the master consists of the 7-bit register address in the lower 7-bits; the MS bit of the byte is ignored and may be 0 or 1. The CMX655D TWI Slave will signal an ACK by driving the SDA line low. The next byte placed on the TWI-bus by the master is the data to be written and the CMX655D TWI Slave responds with an ACK. The TWI master terminates the transfer by generating the STOP condition.

To read from an arbitrary address, the TWI master must first perform a write transaction to establish the register address to be read followed by a repeated START condition (Sr) as shown in Figure 30.



**Figure 30 TWI Read Transfer Address Phase**

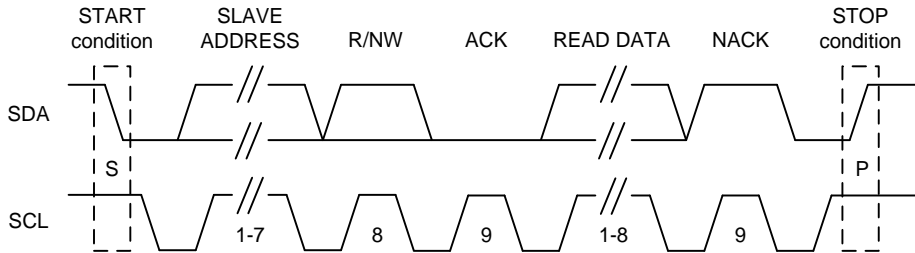
The repeated START condition is functionally identical to the START condition. Following the repeated START condition, the TWI master proceeds to perform a read transaction and resends the 7-bit Slave Address with the R/NW bit set to 1 as shown in Figure 31.



**Figure 31 TWI Read Transfer Data Phase**

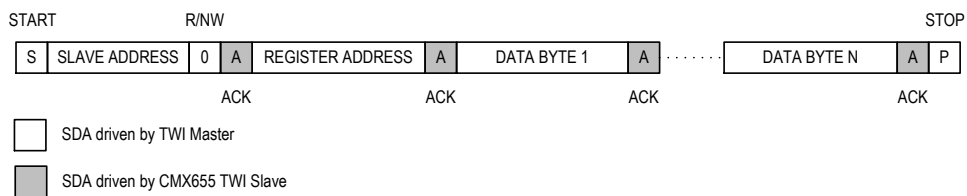
The CMX655D TWI Slave responds with an ACK and drives the read data onto the TWI-bus in the next byte transferred. The CMX655D TWI Slave will send \$FF as the data read from unallocated register addresses. The TWI master responds with a Not Acknowledgement (NACK) which indicates to the CMX655D TWI Slave that it should no longer drive the SDA line in this transfer. This subsequently enables the TWI master to terminate the transfer by generating a STOP condition.

The register address is internally reset by the CMX655D TWI Slave to 0 at the end of each transfer when the STOP condition is detected. This feature allows the CMX655D Interrupt Status Register (ISR) to be immediately read without performing a prior write transaction to establish the register address (Figure 32).

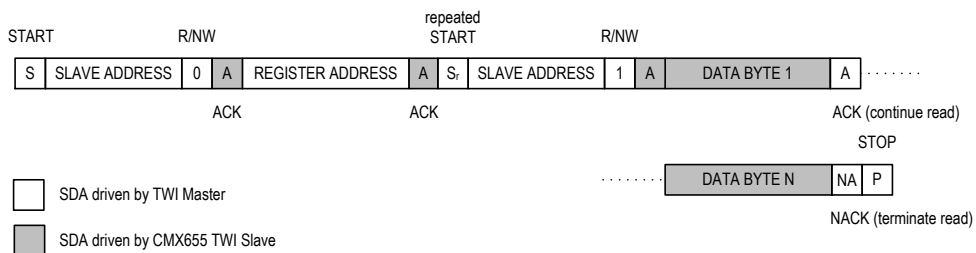


**Figure 32 TWI Interrupt Status Register Read Transfer**

The register address is automatically incremented by the CMX655D internally after each data byte is transferred to accommodate consecutive write (or read) address accesses within the same transfer with reduced protocol overhead as shown in Figure 33 and Figure 34.



**Figure 33 TWI N-Byte Write Transfer**



**Figure 34 TWI N-Byte Read Transfer**

It should be noted that the internal address saturates at \$7F and does not auto-increment to wrap back around to \$00.

## 5.8 Serial Audio Interface

The Serial Audio Interface (SAI) is used to transfer audio data between the CMX655D and an external device. The SAI is configured by the **SAICTRL** and **SAIMUX** registers and is enabled or disabled by the SAI bit in the **SYSCTRL** register. The **SAICTRL** register and the audio companding control bits in the **SAIMUX** register may only be changed while the SAI is disabled.

The CMX655D Serial Audio Interface may be configured to operate as either master or slave. If the CMX655D Serial Audio Interface is the master, the LRCLK/FS and BCLK pins are driven by the CMX655D as outputs. If the CMX655D Serial Audio Interface is the slave, the LRCLK/FS and BCLK pins are configured as inputs and both pins should be driven by the external device. The CMX655D Serial Audio Interface transmits serial audio data to the external device on the SDO output pin and receives serial audio data from the external device on the SDI input pin.

If the CMX655D Serial Audio Interface is disabled, the LRCLK/FS and BCLK pins as are configured as digital inputs with internal pull-up resistors connected to VDD\_AD. The pull-up resistors are disabled when the CMX655D Serial Audio Interface is enabled by the external host. The CMX655D Serial Audio Interface may be configured to operate in several modes and supports the I2S, Left-Justified and PCM audio interface protocols.

Serial data is shifted MSB first in to the CMX655D on SDI and out of the CMX655D on SDO by a common bit clock BCLK. The CMX655D supports back-to-back data transfers in all audio transfer modes.

The standard audio data format is represented as a 16-bit signed number. If  $\mu$ -law or A-law audio companding is selected then the audio data format transferred over the interface is an 8-bit compressed code. Audio companding is only permitted at a sample rate of 8ksps. The audio data output by the CMX655D for a disabled microphone channel is '0'.

By default, serial data changes on the falling edge of BCLK and is sampled on the rising edge of BCLK, though it is possible to configure the CMX655D to transfer data using the opposite edge of BCLK.

### 5.8.1 I2S Mode

The I2S interface consists of a Left/Right clock called LRCLK which has a frequency equal to the sample rate and is common to both input and output audio signal paths. The LRCLK low and high levels indicate if the audio data reflects the left or right channel. BCLK must have a frequency of at least 32xLRCLK for 16-bit signed audio data or at least 16xLRCLK for companded audio data. Serial data is in a left-justified format with the MSB being transmitted one clock cycle after LRCLK changes as shown in Figure .

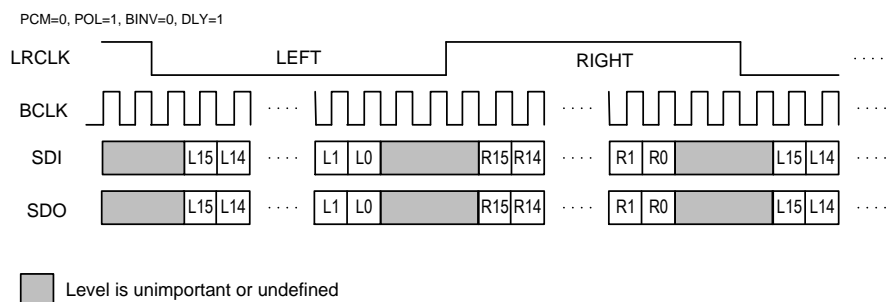
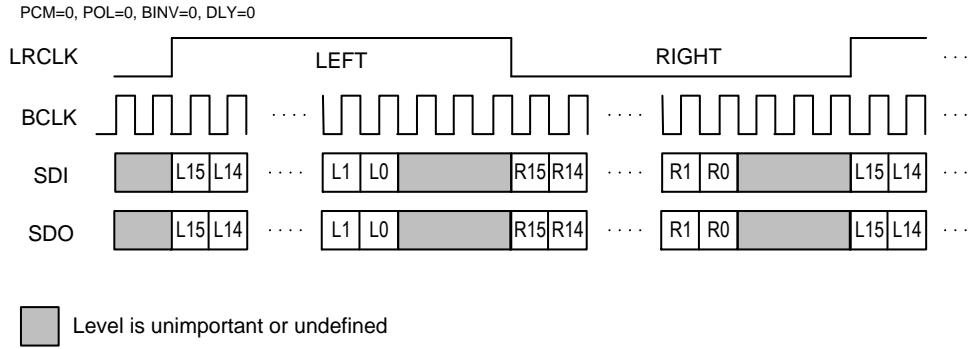


Figure 35 I2S Mode Data Transfer

### 5.8.2 Left-Justified Mode

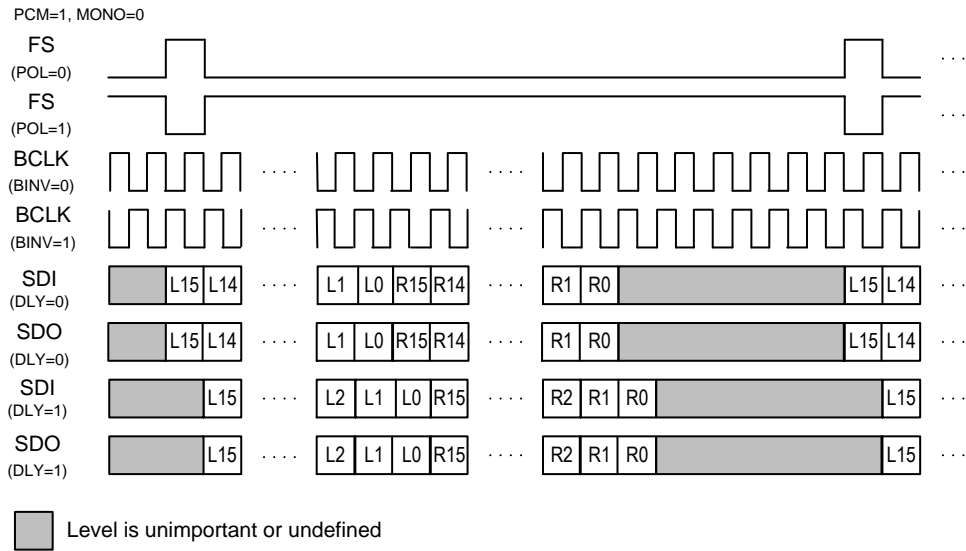
Left-Justified mode is similar to I2S mode except that the polarity of the LRCLK signal is inverted and the MSB of the serial data is transferred in the first cycle following the LRCLK transition, one cycle earlier than I2S mode. Figure 36 shows a Left-Justified mode transfer.



**Figure 36 Left-Justified Mode Data Transfer**

**5.8.3 PCM Mode**

The PCM Mode is a common interface protocol compatible with standard DSP devices for transferring PCM data. A frame sync signal (FS) is used to indicate the audio sample rate and serial data is transferred using a left-justified format. The FS signal is a single BCLK period wide and the MSB of left channel serial data may be configured to be transferred in the first or second cycle following the FS transition. When transferring two channels, the left channel data is first transferred followed by the right channel data. When transferring two channels, BCLK must have a frequency of at least 32xLRCLK for 16-bit signed audio data or at least 16xLRCLK for companded audio data. When transferring a single channel, BCLK must have a frequency of at least 16xLRCLK for 16-bit signed audio data or at least 8xLRCLK for companded audio data. Figure 37 shows an example 2-channel 16-bit PCM mode transfer with different configuration parameters.



**Figure 37 PCM Mode Dual-channel Data Transfer**

Figure 38 shows an example of a single-channel 16-bit PCM mode transfer with different configuration parameters.

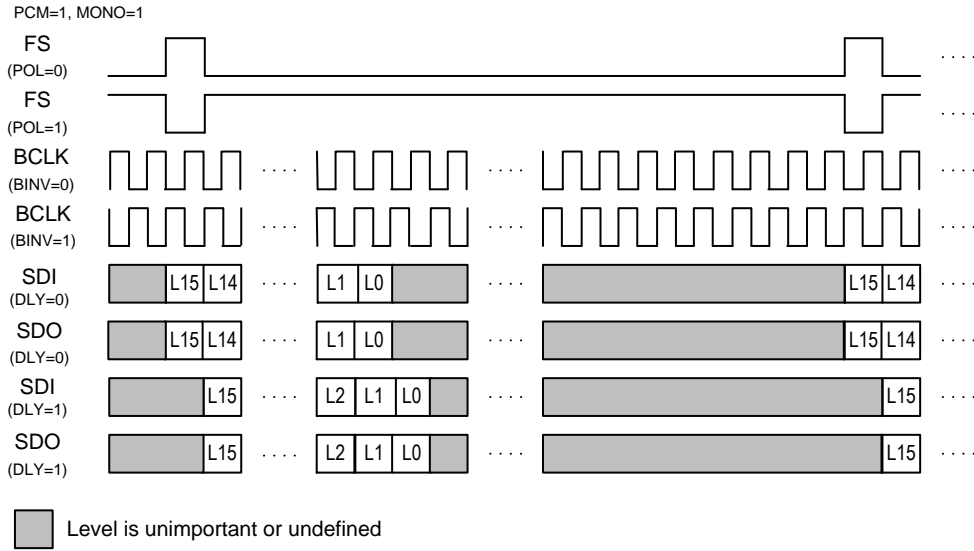


Figure 38 PCM Mode Single-channel Data Transfer

5.8.4 Audio Companding

If the audio sample rate is 8ksp/s, data may be optionally companded using 8-bit  $\mu$ -law or A-law encoding by appropriately programming the COMP and ALAW control bits in the **SAIMUX** register. The 8-bit compressed audio data samples may be transported over the interface using half the number of BCLK cycles than standard 16-bit signed data. Any surplus LSBs transmitted by the CMX655D on SDO are set to '0'. The **SAIMUX** register companding control bits may only be modified while the SAI is disabled. An example of companded data transfer using the CMX655D as a PCM slave is shown in Figure 39.

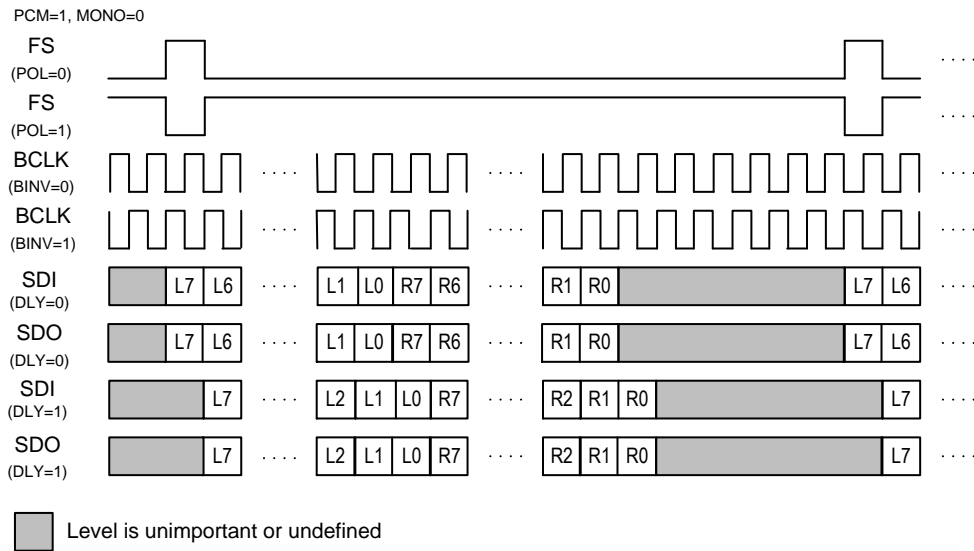


Figure 39 PCM Slave Mode Dual-channel Companded Data Transfer

### 5.8.5 Serial Audio Interface Registers

#### SAICTRL (\$09)

Serial Audio Interface Control (R/W)

Reset Value: \$00

| 7    | 6  | 5    | 4   | 3   | 2    | 1 | 0   |
|------|----|------|-----|-----|------|---|-----|
| MSTR | WL | MONO | DLY | POL | BINV | 0 | PCM |

#### MSTR Serial Audio Interface Master

- 0 CMX655D is the slave and the external master drives LRCLK/FS and BCLK
- 1 CMX655D is the master and drives LRCLK/FS and BCLK

#### WL Word length per channel transmitted by the CMX655D if MSTR=1

- 0 16-bits for standard data or 8-bits for companded data
- 1 32-bits for standard data or 16-bits for companded data

#### MONO Mono Data (only applicable if PCM=1)

- 0 Frame contains both left and right data
- 1 Frame contains only left data

#### DLY Data Delay

- 0 SDI/SDO are latched/valid on the 1<sup>st</sup> BCLK edge following the LRCLK/FS transition
- 1 SDI/SDO are latched/valid on the 2<sup>nd</sup> BCLK edge following the LRCLK/FS transition

#### POL Polarity

- 0 If PCM=0, Left data if LRCLK=1 and right data if LRCLK=0.  
If PCM=1, Start of frame indicated by FS=1.
- 1 If PCM=0, Left data if LRCLK=0 and right data if LRCLK=1.  
If PCM=1, Start of frame indicated by FS=0.

#### BINV BCLK Invert

- 0 SDI/SDO and LRCLK/FS change on the negative edge of BCLK.  
SDI/SDO latched/valid on the positive edge of BCLK.
- 1 SDI/SDO and LRCLK/FS change on the positive edge of BCLK.  
SDI/SDO latched/valid on the negative edge of BCLK.

#### PCM PCM Mode

- 0 The LRCLK/FS phase is used to indicate Left or Right channel data
- 1 The LRCLK/FS is used for frame synchronization and serial data is always left-justified

The sample bit-width is 16-bits for standard data and 8-bits for companded data.

For non-PCM modes (PCM = 0) the transmitted word length may be greater than or less than or equal to the sample bit-width.

For PCM slave mode (PCM = 1, MSTR=0) the transmitted word length must be equal to the sample-bit width.

If the transmitted word length is less than the sample bit-width, the non-received input word LSBs are set to zero internally and the output word LSBs are not transmitted.

If the transmitted word length is greater than the sample bit-width, the surplus received input LSBs are ignored and the surplus transmitted output LSBs are set to zero.

**SAIMUX (\$0A)**

Serial Audio Interface Mux (R/W)

Reset Value: \$00

| 7 | 6 | 5    | 4    | 3   | 2 | 1   | 0 |
|---|---|------|------|-----|---|-----|---|
| 0 |   | ALAW | COMP | AMP |   | MIC |   |

**ALAW****Companding Law**

|   |       |
|---|-------|
| 0 | μ-Law |
| 1 | A-Law |

**COMP****Companding Enable (requires CLKCTRL.SR=0)**

|   |  |
|---|--|
| 0 | Companding disabled at 8ksps (16-bit data) |
| 1 | Companding enabled at 8ksps (8-bit data)   |

**AMP****Amplifier Input Data**

|     |                             |
|-----|-----------------------------|
| 0   | Left data                   |
| 1   | Right data                  |
| 2-3 | Mean of left and right data |

**MIC****Microphone Output Data**

|   |  |
|---|--|
| 0 | Left data is microphone left channel, right data is microphone right channel |
| 1 | Left data is microphone right channel, right data is microphone left channel |
| 2 | Left and right data are microphone left channel                              |
| 3 | Left and right data are microphone right channel                             |

**5.9 Interrupt Status and IRQN Pin**

The active low IRQN pin is driven low when an interrupt status request bit in the **ISR** register is high and the associated interrupt status mask bit in the **ISM** register is set high. The **ISR** register interrupt status bits are cleared down when the **ISR** register is read. Some of the interrupt status events may be optionally enabled using the **ISE** register.

**5.9.1 Interrupt Registers****ISR (\$00)**

Interrupt Status Register (R)

Reset Value: \$00

| 7 | 6   | 5     | 4      | 3       | 2     | 1    | 0    |
|---|-----|-------|--------|---------|-------|------|------|
| 0 | VOL | THERM | CLKRDY | AMPCLIP | AMPOC | MICL | MICR |

If a bit is set to 1, it indicates that the corresponding event has occurred.

|                |  |
|----------------|--|
| <b>VOL</b>     | Volume gain adjustment completed.  |
| <b>THERM</b>   | Thermal warning indication (auto power amplifier shut-off).                            |
| <b>CLKRDY</b>  | Main clock ready – this bit is set once the clock status goes from inactive to active. |
| <b>AMPCLIP</b> | Class-D amplifier output clipping (saturation) detected.                               |
| <b>AMPOC</b>   | Class-D amplifier overload current detected (auto power amplifier shut-off).           |
| <b>MICL</b>    | Microphone left channel level has exceeded threshold.                                  |
| <b>MICR</b>    | Microphone right channel level has exceeded threshold.                                 |

The **ISR** register is automatically cleared to 0 when read.

If **VOL** is set to 1, the **VOL** bit in the **ISE** register is automatically cleared to 0 thereby preventing further **VOL** interrupt events from being generated. The **VOL** bit in the **ISE** register may not be set again until the **VOL** **ISR** register bit has been cleared to 0.

If **THERM** or **AMPOC** is set to 1, the **PAMP** **SYSCTRL** register bit is automatically cleared thereby disabling the power-amplifier and preventing further generation **THERM** or **AMPOC** interrupt events. The **PAMP** **SYSCTRL** register bit may not be set to 1 again until **THERM** and **AMPOC** **ISR** register bits have been cleared to 0.

If AMPCLIP is set to 1, the AMPCLIP **ISE** register bit is automatically cleared to 0 thereby preventing the clipping detection circuit from generating further AMPCLIP interrupt events. The AMPCLIP **ISE** register bit may not be set again until the AMPCLIP **ISR** register bit has been cleared to 0.

If MICL/MICR is set to 1, the MICL/MICR **ISE** register bit is automatically cleared to 0 thereby preventing the left/right channel record level detection block from generating further MICL/MICR interrupt events. The MICL/MICR **ISE** register bit may not be set again until the MICL/MICR **ISR** register bit has been cleared to 0.

### ISM (\$01)

Interrupt Status Mask (R/W)

Reset Value: \$00

| 7 | 6   | 5     | 4      | 3       | 2     | 1    | 0    |
|---|-----|-------|--------|---------|-------|------|------|
| 0 | VOL | THERM | CLKRDY | AMPCLIP | AMPOC | MICL | MICR |

Interrupt request mask for the interrupt status bits in the **ISR** register.

If a bit is set to 0, the corresponding **ISR** bit has no effect on the IRQN pin.

If a bit is set to 1, the IRQN pin will go low if the corresponding **ISR** bit is 1.

### ISE (\$02)

Interrupt Status Enable (R/W)

Reset Value: \$00

| 7 | 6   | 5 | 4 | 3       | 2 | 1    | 0    |
|---|-----|---|---|---------|---|------|------|
| 0 | VOL | 0 | 0 | AMPCLIP | 0 | MICL | MICR |

#### **VOL** Volume Interrupt Enable

0 VOL interrupt disabled. Volume gain adjustment completion will not set **ISR** VOL bit to 1.

1 VOL interrupt enabled. Volume gain adjustment completion will set **ISR** VOL bit to 1.  
VOL is automatically cleared to 0 when **ISR** VOL bit is set to 1.

#### **AMPCLIP** Amplifier Clipping Interrupt Enable

0 AMPCLIP interrupt disabled. A clipping event will not set **ISR** AMPCLIP bit to 1.

1 AMPCLIP interrupt enabled. A clipping event will set **ISR** AMPCLIP bit to 1.  
AMPCLIP is automatically cleared to 0 when **ISR** AMPCLIP bit is set to 1.

#### **MICL** Microphone Left Channel Level Detection Interrupt Enable

0 MICL interrupt disabled. A left channel level detection event will not set **ISR** MICL bit to 1.

1 MICL interrupt enabled. A left channel level detection event will set **ISR** MICL bit to 1.  
MICL is automatically cleared to 0 when **ISR** MICL bit is set to 1. This bit is equivalent to and its state is always the same as that of the LEN bit in the **LDCTRL** register.

#### **MICR** Microphone Right Channel Level Detection Interrupt Enable

0 MICR interrupt disabled. A right channel level detection event will not set **ISR** MICR bit to 1.

1 MICR interrupt enabled. A right channel level detection event will set **ISR** MICR bit to 1.  
MICR is automatically cleared to 0 when **ISR** MICR bit is set to 1. This bit is equivalent to and its state is always the same as that of the REN bit in the **RDCTRL** register.

## 5.10 System Control

The Serial Audio Interface, Lineout, Power amplifier and digital Microphone channels are enabled using the **SYSCTRL** register. The main clock must first be configured as described in section 5.3 and activated using the **COMMAND** register before **SYSCTRL** may be modified.

### 5.10.1 System Control Registers

#### **SYSCTRL** (\$32)

System Control (R/W)

Reset Value: \$00

| 7 | 6 | 5   | 4    | 3    | 2 | 1    | 0    |
|---|---|-----|------|------|---|------|------|
| 0 | 0 | SAI | LOUT | PAMP | 0 | MICL | MICR |



|             |   |
|-------------|---|
| <b>SAI</b>  | <b>Serial Audio Interface</b>   |
| 0           | Serial Audio Interface disabled.  |
| 1           | Serial Audio Interface enabled.   |
| <b>LOUT</b> | <b>Lineout</b>  |
| 0           | Lineout disabled.   |
| 1           | Lineout enabled.  |
| <b>PAMP</b> | <b>Power Amplifier</b>  |
| 0           | Power amplifier disabled.   |
| 1           | Power amplifier enabled.  |
|             | PAMP is automatically cleared to 0 if the <b>ISR</b> AMPOC or <b>THERM</b> bits are set to 1. |
| <b>MICL</b> | <b>Microphone Left Channel</b>  |
| 0           | Microphone left channel disabled.   |
| 1           | Microphone left channel enabled.  |
| <b>MICR</b> | <b>Microphone Right Channel</b>   |
| 0           | Microphone right channel disabled.  |
| 1           | Microphone right channel enabled.   |

**COMMAND (\$33)**

Command Register (W)

Reset Value: \$00

|     |   |   |   |   |   |   |   |
|-----|---|---|---|---|---|---|---|
| 7   | 6 | 5 | 4 | 3 | 2 | 1 | 0 |
| CMD |   |   |   |   |   |   |   |

|            |  |
|------------|--|
| <b>CMD</b> | <b>Command</b>   |
| \$00       | Clock Stop.  |
| \$01       | Clock Start.   |
| \$02-\$FE  | Reserved.  |
| \$FF       | Soft Reset (sets all registers back to their reset value). |

This register will always be read back as 0.

**5.11 Register Address Map**

All device registers are byte addressable. Programmable fields that occupy consecutive byte address locations will be updated with the new written value following a write to the least-significant address byte of the field which resides in the upper address location. Registers which require the main clock to be active are indicated by Yes in the Main Clock column of Table 9 and accesses to these registers should not be attempted if the main clock is inactive.

**Table 9 Register Address Map**

| Address                       | Register       | Description                    | Reset | R/W | Main Clock |
|-------------------------------|----------------|--------------------------------|-------|-----|------------|
| <b>Interrupt and Status</b>   |                |                                |       |     |            |
| \$00                          | <b>ISR</b>     | Interrupt Status Register      | \$00  | R   | No         |
| \$01                          | <b>ISM</b>     | Interrupt Status Mask          | \$00  | R/W | No         |
| \$02                          | <b>ISE</b>     | Interrupt Status Enable        | \$00  | R/W | Yes        |
| <b>Clock &amp; PLL</b>        |                |                                |       |     |            |
| \$03                          | <b>CLKCTRL</b> | Clock Control                  | \$00  | R/W | No         |
| \$04                          | <b>RDIVHI</b>  | R-Divider High Byte            | \$00  | R/W | No         |
| \$05                          | <b>RDIVLO</b>  | R-Divider Low Byte             | \$00  | R/W | No         |
| \$06                          | <b>NDIVHI</b>  | N-Divider High Byte            | \$00  | R/W | No         |
| \$07                          | <b>NDIVLO</b>  | N-Divider Low Byte             | \$00  | R/W | No         |
| \$08                          | <b>PLLCTRL</b> | PLL Control                    | \$00  | R/W | No         |
| <b>Serial Audio Interface</b> |                |                                |       |     |            |
| \$09                          | <b>SAICTRL</b> | Serial Audio Interface Control | \$00  | R/W | Yes        |
| \$0A                          | <b>SAIMUX</b>  | Serial Audio Interface Mux     | \$00  | R/W | Yes        |
| <b>Record</b>                 |                |                                |       |     |            |
| \$0C                          | <b>RVF</b>     | Record Voice Filters           | \$00  | R/W | Yes        |

|                       |                 |                                 |      |     |     |
|-----------------------|-----------------|---------------------------------|------|-----|-----|
| \$0D                  | <b>LDCTRL</b>   | Left Channel Detection Control  | \$00 | R/W | Yes |
| \$0E                  | <b>RDCTRL</b>   | Right Channel Detection Control | \$00 | R/W | Yes |
| \$0F                  | <b>LEVEL</b>    | Record Level                    | \$00 | R/W | Yes |
| \$1C                  | <b>NGCTRL</b>   | Noise Gate Control              | \$00 | R/W | Yes |
| \$1D                  | <b>NGTIME</b>   | Noise Gate Time                 | \$00 | R/W | Yes |
| \$1E                  | <b>NGLSTAT</b>  | Noise Gate Left Channel Status  | \$00 | R   | Yes |
| \$1F                  | <b>NGRSTAT</b>  | Noise Gate Right Channel Status | \$00 | R   | Yes |
| <b>Playback</b>       |                 |                                 |      |     |     |
| \$28                  | <b>PVF</b>      | Playback Voice Filters          | \$00 | R/W | Yes |
| \$29                  | <b>PREAMP</b>   | Playback Preamp Gain            | \$00 | R/W | Yes |
| \$2A                  | <b>VOLUME</b>   | Playback Volume                 | \$00 | R/W | Yes |
| \$2B                  | <b>ALCCTRL</b>  | ALC Control                     | \$00 | R/W | Yes |
| \$2C                  | <b>ALCTIME</b>  | ALC Time                        | \$00 | R/W | Yes |
| \$2D                  | <b>ALCGAIN</b>  | ALC Make-up Gain                | \$00 | R/W | Yes |
| \$2E                  | <b>ALCSTAT</b>  | ALC Status                      | \$00 | R   | Yes |
| \$2F                  | <b>DST</b>      | Digital Side Tone Control       | \$00 | R/W | Yes |
| \$30                  | <b>CPR</b>      | Click-and-Pop Reduction         | \$00 | R/W | Yes |
| <b>General System</b> |                 |                                 |      |     |     |
| \$32                  | <b>SYSCTRL</b>  | System Control                  | \$00 | R/W | Yes |
| \$33                  | <b>COMMAND</b>  | Command Register                | \$00 | W   | No  |
| <b>Reserved</b>       |                 |                                 |      |     |     |
| \$34                  | <b>RESERVED</b> | Not for customer use.           | \$29 | R/W | Yes |
| \$35                  | <b>RESERVED</b> | Not for customer use.           | \$40 | R/W | Yes |
| \$36                  | <b>RESERVED</b> | Not for customer use.           | \$80 | R/W | Yes |
| \$37                  | <b>RESERVED</b> | Not for customer use.           | \$80 | R/W | Yes |

**Notes:**

- All registers will retain data if VDD\_AD pin is held high, even if all other power supply pins are disconnected.
- The data interface can run at a lower voltage than the Class D Amplifier section of the device by setting the VDD\_AD supply to the required interface voltage, in the range 1.75 V to 3.6 V.
- The CLKCTRL register may only be modified if the main clock is inactive.
- If clock and data lines are shared with other devices VDD\_AD must be maintained in its normal operating range otherwise ESD protection diodes may cause a problem with loading signals connected to SCLK, MISO and MOSI pins, preventing correct programming of other devices. Other supplies may be turned off and all circuits on the device may be powered down without causing this problem.

## 6 Application Notes

### 6.1 Programming Examples

Notes:

- After device reset, the first main clock source to be configured must always be the integrated low power oscillator (LPOSC), and then the main clock must then be started. Thereafter, the main clock source can be reconfigured.
- While LPOSC is the main clock source, both Serial Audio Interface and Class-D Amplifier subsystems must be disabled.
- The main clock must be stopped while the main clock source is being configured or reconfigured.
- Writes to the **CLKCTRL** register simultaneously configure the main clock and codec sample rate.
- Reading the **ISR** register clears all its bits.

#### 6.1.1 Required First Main Clock Configuration

- While holding the SPIS pin (SPI Select) state to select the desired Control Interface type, reset the device by powering-up the VDD\_AD and VDD\_PA unregulated supplies.
- Configure the main clock source to LPOSC and codec sample rate, then start the main clock.

| R/W | Register       | Address | Data | Notes   |
|-----|----------------|---------|------|---|
| W   | <b>CLKCTRL</b> | \$03    | \$24 | 16ksps, main clock source = LPOSC. (Any other valid codec sample rate may be selected.) |
| W   | <b>COMMAND</b> | \$33    | \$01 | Issue Clock Start command.  |

- Poll (read) the **ISR** register until its CLKRDY b4 is set.

| R/W | Register   | Address | Data | Notes                                    |
|-----|------------|---------|------|--|
| R   | <b>ISR</b> | \$00    | \$10 | CLKRDY b4 should eventually be set to 1. |

The main clock should now be running, using LPOSC as its source.

#### 6.1.2 Reconfigure Main Clock Source to 24.576 MHz RCLK External Input Signal

To change main clock source to an externally applied 24.576 MHz RCLK input signal and also select 16ksps codec sample rate:

| R/W | Register       | Address | Data | Notes  |
|-----|----------------|---------|------|--|
| W   | <b>COMMAND</b> | \$33    | \$00 | Issue Clock Stop command.  |
| W   | <b>CLKCTRL</b> | \$03    | \$20 | 16ksps, main clock source = RCLK divided by 1 (so the externally applied RCLK signal must be 24.576MHz). |

- Poll (read) the **ISR** register until its CLKRDY b4 is set.

|   |                |      |      |                       |
|---|----------------|------|------|-----------------------|
| W | <b>COMMAND</b> | \$33 | \$01 | Start the main clock. |
|---|----------------|------|------|-----------------------|

- Poll (read) the **ISR** register until its CLKRDY b4 is set. Note that reading the **ISR** register clears all its bits.

| R/W | Register   | Address | Data | Notes                                    |
|-----|------------|---------|------|--|
| R   | <b>ISR</b> | \$00    | \$10 | CLKRDY b4 should eventually be set to 1. |

The main clock should now be running, using the external 24.576MHz RCLK signal as its source.

### 6.1.3 Reconfigure Main Clock Source to PLL, Using 16 kHz LRCLK/FS External Input Signal as its Reference

To change main clock source to the CMX655D integrated clock PLL subsystem, using the device's Serial Audio Interface (SAI) LRCLK/FS external input signal as the PLL's reference input:

- The starting point for this example is that CMX655D main clock is running and using the external 24.576MHz RCLK external input signal as its source.
- The SAI will be configured
- To clock the CMX655D PLL from the SAI LRCLK/FS external input signal and operate the CMX655D codes at 16ksps:
  - the SAI subsystem must be configured to operate as a slave,
  - the clock PLL must be configured and
  - the external SAI master must continuously apply a 16 kHz LRCLK/FS signal that serves as the PLL's reference clock (REFCLK).

| R/W | Register       | Address | Data | Notes  |
|-----|----------------|---------|------|--|
| W   | <b>SYSCTRL</b> | \$32    | \$00 | Disable Serial Audio Interface, Lineout, Power Amplifier, Microphone Left Channel, and Microphone Right Channel  |
| W   | <b>SAICTRL</b> | \$09    | \$18 | Configure SAI for I2S format <ul style="list-style-type: none"> <li>• MSTR b7 = 0: SAI is slave and LRCLK/FS and BCLK are digital inputs</li> <li>• WL b6 = 0: moot; applies only if b7 = 1</li> <li>• MONO b5 = 0: moot; applies only if b0 = 1</li> <li>• DLY b4 = 1: SDI/SDO are latched/valid on the 2<sup>nd</sup> BCLK edge following the LRCLK/FS transition</li> <li>• POL b3 = 1: If PCM=0, Left data if LRCLK=0 and right data if LRCLK=1</li> <li>• BINV b2 = 0: SDI/SDO and LRCLK/FS change on BCLK negative edge, SDI/SDO are latched on BCLK positive edge</li> <li>• b1 = 0: not used</li> <li>• PCM b0 = 0: LRCLK/FS phase indicates Left or Right data channel</li> </ul> |
| W   | <b>COMMAND</b> | \$33    | \$00 | Issue Clock Stop command   |
| W   | <b>RDIVHI</b>  | \$04    | \$00 | Set RDIV b12:8   |
| W   | <b>RDIVLO</b>  | \$05    | \$01 | Set RDIV b7:0 = 1 so RDIV b12:0 = 0d1  |
| W   | <b>NDIVHI</b>  | \$06    | \$06 | Set NDIV b12:8   |
| W   | <b>NDIVLO</b>  | \$07    | \$00 | Set NDIV b7:0 = 0 so NDIV b12:0 = 0x600 = 0d1536 so PLL VCO will stabilize at 1536 * 16 kHz = 24.576 MHz   |
| W   | <b>PLLCTRL</b> | \$08    | \$03 | PLLCTRL b7:4 = 0x0 = 17.5 kohm Loop Filter Resistor<br>PLLCTRL b3:0 = 0x3 = 0.1 uA/cycle Charge Pump Current Gain  |
| W   | <b>CLKCTRL</b> | \$03    | \$20 | 16ksps, main clock source = RCLK divided by 1 (so the externally applied RCLK signal must be 24.576MHz).   |

- Poll (read) the **ISR** register until its CLKRDY b4 is set.

|   |                |      |      |                       |
|---|----------------|------|------|-----------------------|
| W | <b>COMMAND</b> | \$33 | \$01 | Start the main clock. |
|---|----------------|------|------|-----------------------|

- Poll (read) the **ISR** register until its CLKRDY b4 is set. Note that reading the **ISR** register clears all its bits.

| R/W | Register   | Address | Data | Notes                                    |
|-----|------------|---------|------|--|
| R   | <b>ISR</b> | \$00    | \$10 | CLKRDY b4 should eventually be set to 1. |

The main clock should now be running, using the external 24.576MHz RCLK signal as its source.

**6.1.4 Configuration**

- Configure the Serial Audio Interface and record and/or playback channels.

| R/W | Register | Address | Data | Notes   |
|-----|----------|---------|------|---|
| W   | SAICTRL  | \$09    | \$98 | I2S master mode.  |
| W   | SAIMUX   | \$0A    | \$08 | Use the mean of left and right input data for playback. |
| W   | LEVEL    | \$0F    | \$CC | Record level gains set to 0dB.                          |
| W   | VOLUME   | \$2A    | \$D5 | Playback volume gain set to -6dB with smoothing.        |
| ... | ...      | ...     | ...  | Configure audio signal processing blocks as required.   |

**6.1.5 Enable Audio Channels**

- Enable the Serial Audio Interface and record and/or playback channels.

| R/W | Register | Address | Data | Notes  |
|-----|----------|---------|------|--|
| W   | SYSCTRL  | \$32    | \$2B | Enable SAI, left and right microphone record channels and the Class-D power-amplifier. |

**6.1.6 Shutdown**

- Mute the playback volume if the Class-D amplifier is enabled.

| R/W | Register | Address | Data | Notes  |
|-----|----------|---------|------|--|
| W   | VOLUME   | \$2A    | \$80 | Playback volume gain set to mute with smoothing. |
| W   | ISM      | \$01    | \$00 | Prevents all device events from asserting IRQN.  |

- Poll (read) the ISR register until its VOL b6 is set.

| R/W | Register | Address | Data | Notes   |
|-----|----------|---------|------|---|
| R   | ISR      | \$00    | \$40 | VOL b6 should eventually be set to 1, when the volume adjustment completes. |

- Disable the Serial Audio Interface and record and/or playback channels and stop the main clock.

| R/W | Register | Address | Data | Notes   |
|-----|----------|---------|------|---|
| W   | SYSCTRL  | \$32    | \$00 | Disable SAI and all record/playback channels. |
| W   | COMMAND  | \$33    | \$00 | Stop the main clock.                          |

### 6.1.7 Shutdown Using an Interrupt

The CMX655D indicates Interrupt Service Enabled events by setting event-specific Interrupt Status Register **ISR** (\$00) bits. If an **ISR** bit is set while its corresponding Interrupt Status Mask **ISM** (\$01) register mask bit is set, the device's IRQN pin will assert low. Most **ISR** bits also have a corresponding bit in the Interrupt Status Enable **ISE** (\$02) register. **ISE** bits are used to ensure that a single event is not reported multiple times. See the **ISR** and **ISE** descriptions for complete details.

This is an interrupt-driven version of the 6.1.6 Shutdown example.

- Mute the playback volume if the Class-D amplifier is enabled.

| R/W | Register      | Address | Data | Notes  |
|-----|---------------|---------|------|--|
| W   | <b>VOLUME</b> | \$2A    | \$80 | Playback volume gain set to mute with smoothing.   |
| W   | <b>ISM</b>    | \$01    | \$40 | IRQN will go low when volume adjustment completes. |
| W   | <b>ISE</b>    | \$02    | \$40 | Enable volume interrupt generation.                |

- Wait for the IRQN line to go low when volume adjustment completes, then read the **ISR** register to confirm that the completion of volume adjustment is indicated.

| R/W | Register   | Address | Data | Notes                    |
|-----|------------|---------|------|--------------------------|
| R   | <b>ISR</b> | \$00    | \$40 | Expect VOL bit set to 1. |

If the VOL **ISM** register bit is not set to 1, IRQN was asserted by a different, simultaneously enabled interrupted event, in which case the **ISR** register may be polled until volume adjustment completes and sets the VOL bit.

- Disable the Serial Audio Interface and record and/or playback channels and stop the main clock.

| R/W | Register       | Address | Data | Notes   |
|-----|----------------|---------|------|---|
| W   | <b>SYSCTRL</b> | \$32    | \$00 | Disable SAI and all record/playback channels. |
| W   | <b>COMMAND</b> | \$33    | \$00 | Stop the main clock.                          |

## 7 Performance Specification

### 7.1 Electrical Performance

#### 7.1.1 Absolute Maximum Ratings

Exceeding these maximum ratings can result in damage to the device.

|  | Min. | Max.                   | Units |
|--|------|------------------------|-------|
| Supply (VDD_AD - DGND) or (VDD_PA - VSS_PA)                  | -0.3 | +3.6                   | V     |
| Voltage on any pin to VSS_PA or DGND                         | -0.3 | V <sub>max</sub> + 0.3 | V     |
| Voltage between VSS_PA pins and DGND                         | -50  | +50                    | mV    |
| Current into or out of pins, connected to:                   |      |                        |       |
| VDD_AD, DGND   | -100 | +100                   | mA    |
| VDD_PA, VSS_PA   | -800 | +800                   | mA    |
|  | Min. | Max.                   | Units |
| Total Allowable Power Dissipation at T <sub>AMB</sub> = 25°C | –    | 2290                   | mW    |
| Storage Temperature  | -50  | +125                   | °C    |
| Operating Air Temperature (T <sub>AMB</sub> )                | -40  | +85                    | °C    |
| Thermal Resistance R <sub>JC</sub>                           |      | 3                      | °C/W  |
| Maximum Allowable Junction Temperature                       |      | 125                    | °C    |

Note: Junction-to-ambient thermal resistance is dependent on board layout and mounting arrangements. Case temperature refers to the temperature of the exposed paddle on the underside of the package. Careful layout of the PCB is essential for best performance.

#### 7.1.2 Operating Limits

For the following conditions unless otherwise specified:  
VSS\_PA = DGND = 0V; and T<sub>AMB</sub> = +25°C.

|  | Notes | Min.              | Max. | Units |
|--|-------|-------------------|------|-------|
| Class-D Amplifier Supply (VDD_PA - VSS_PA) |       | 2.7               | 3.6  | V     |
| Analogue/Digital Supply (VDD_AD - DGND)    |       | 1.75 <sup>2</sup> | 3.6  | V     |

#### Notes

- 2 Requires VDD\_PA to be unpowered, otherwise 2.7V if VDD\_PA is powered.

### 7.1.3 Operating Characteristics

#### 7.1.3.1 DC Parameters

For the following conditions unless otherwise specified:  
VDD\_AD = 1.75V to 3.6V; VDD\_PA = 2.7V to 3.6V; VSS\_PA = DGND = 0V; and T<sub>AMB</sub> = +25°C.

| DC Parameters   | Notes | Min.        | Typ.         | Max.        | Units |
|---|-------|-------------|--------------|-------------|-------|
| Total Current Consumption   |       |             |              |             |       |
| Standby - main clock enabled and sourced directly from RCLK                               |       |             | 260          |             | μA    |
| Standby – main clock enabled and sourced directly from PLL                                | 3     |             | 380          |             | μA    |
| Standby – main clock enabled and sourced directly from LPOSC                              |       |             | 240          |             | μA    |
| Class-D Power Amplifier @ 1W output   | 4     |             | 1            |             | mA    |
| Class-D Lineout Amplifier @ 0.25mW output   | 5     |             | 9            |             | mA    |
| Stereo record channels with digital microphones and main clock sourced directly from RCLK | 6     |             | 500          |             | μA    |
| Mono record channel with digital microphone and main clock sourced from internal LPOSC    | 7     | -           | 440          |             | μA    |
| Mono record channel with digital microphone and main clock sourced directly from RCLK     |       |             | 480          |             | μA    |
| Logic '1' Input Level   |       |             |              |             |       |
| VDD_AD = 1.8/2.5/3.3V   |       | 1.2/1.7/2.0 | -            | -           | V     |
| Logic '0' Input Level   |       |             |              |             |       |
| VDD_AD = 1.8/2.5/3.3V   |       | -           | -            | 0.6/0.7/0.8 | V     |
| Logic '1' Output Level  |       |             |              |             |       |
|   |       | VDD_AD -0.4 | -            | -           | V     |
| Logic '0' Output Level  |       |             |              |             |       |
|   |       | -           | -            | 0.4         | V     |
| Digital IO Source/Sink Current Limit  | 8     |             |              |             |       |
| VDD_AD = 1.8/2.5/3.3V   |       |             | 1.25/2.0/2.5 |             | mA    |
| SDA Sink Current Limit when SPIS=0 (I <sub>OL</sub> )                                     |       |             |              |             |       |
| VDD_AD = 1.8/2.5/3.3V   |       |             | 3.75/6.0/7.5 |             | mA    |
| Digital IO pin capacitance  |       |             | 2            |             | pF    |

#### Notes

- 3 PLL reference clock sourced from RCLK
- 4 4Ω load with VDD\_PA at 3.3V
- 5 Load impedance of 18kΩ in parallel with 120pF
- 6 Normal operating mode @ 8ksps
- 7 Autonomous low-power listening mode @ 8ksps, Serial Audio interface disabled
- 8 Applies to all digital pins when SPIS=1; applies to all digital pins except SDA when SPIS=0



### 7.1.3.2 AC Parameters

For the following conditions unless otherwise specified:  
 VDD\_AD = 1.75V to 3.6V; VDD\_PA = 2.7V to 3.6V; VSS\_PA = DGND = 0V; 48ksps and T<sub>AMB</sub> = +25°C.  
 Please refer to section 7.2.1 for other sample rates.

| AC Parameters                       | Notes | Min.  | Typ.   | Max.  | Units |
|-------------------------------------|-------|-------|--------|-------|-------|
| <b>Class-D Power Amplifier</b>      |       |       |        |       |       |
| Speaker Load                        |       |       | 4 to 8 |       | Ω     |
| Output Power                        | 9     |       | 1      |       | W     |
|                                     | 9a    |       | 0.7    |       | W     |
| Overload Current Protection         |       |       | 1.5    |       | A     |
| THD+N @ 48ksps                      | 10,11 |       | 1      |       | %     |
| SNR @ 48ksps                        | 10,11 |       | 81     |       | dB    |
| Efficiency @ 0.5W output power      | 10    |       | 91     |       | %     |
| <b>Class-D Lineout Amplifier</b>    |       |       |        |       |       |
| Line out load impedance             | 12    |       | 18     |       | kΩ    |
| Output Power                        | 12,13 |       | 0.25   |       | mW    |
| THD+N @ 48ksps                      | 12,13 |       | 0.018  |       | %     |
| SNR @ 48ksps                        | 12,13 |       | 76     |       | dB    |
| <b>Microphone Digital Interface</b> |       |       |        |       |       |
| MICCLK Frequency <sup>3</sup>       |       | 2.048 |        | 3.072 | MHz   |
| MICCLK Duty Cycle                   |       |       | 50     |       | %     |
| <b>Record Level Control</b>         |       |       |        |       |       |
| Gain Range                          |       | -12   |        | 3     | dB    |
| Gain Step                           |       |       | 1      |       | dB    |
| <b>Noise Gate</b>                   |       |       |        |       |       |
| Gain Range                          |       | -31   |        | 0     | dB    |
| Gain Step                           |       |       | 1      |       | dB    |
| Threshold Level                     |       | -63   |        | -32   | dBFS  |
| Threshold Step                      |       |       | 1      |       | dB    |
| Expansion Ratio                     |       | 1:2   |        | 1:4   |       |
| Attack Time                         |       | 1.5   |        | 96    | ms    |
| Release Time                        |       | 0.06  |        | 7.68  | s     |
| <b>Automatic Level Control</b>      |       |       |        |       |       |
| Gain Range                          |       | 0     |        | 12    | dB    |
| Gain Step                           |       |       | 1      |       | dB    |
| Threshold Level                     |       | -31   |        | 0     | dBFS  |
| Threshold Step                      |       |       | 1      |       | dB    |
| Compression Ratio                   |       | 1:1.5 |        | 1:∞   |       |
| Attack Time                         |       | 1.5   |        | 96    | ms    |
| Release Time                        |       | 0.06  |        | 7.68  | s     |
| <b>Playback Volume Control</b>      |       |       |        |       |       |
| Gain Range                          |       | -90   |        | 0     | dB    |
| Gain Step                           |       |       | 1      |       | dB    |

#### Notes

- 9 Average power into 4Ω load, VDD\_AD = VDD\_PA = 3.3V with max input level  
 9a Average power into 8Ω load, VDD\_AD = VDD\_PA = 3.3V with max input level  
 10 With 8Ω load, VDD\_AD = VDD\_PA = 3.3V  
 11 A-weighted, 20Hz-20kHz, 0.5W output power  
 12 Nominal lineout load impedance is 18kΩ in parallel with 120pF  
 13 Average power into nominal load impedance, VDD\_AD = VDD\_PA = 3.3V with max. input level

| AC Parameters                                | Notes | Min.  | Typ.                      | Max.  | Units |
|--|-------|-------|---------------------------|-------|-------|
| <b>Playback Preamplifier</b>                 |       |       |                           |       |       |
| Gain Range                                   |       | 0     |                           | 18    | dB    |
| Gain Step                                    |       |       | 6                         |       | dB    |
| <b>Digital Sidetone</b>                      |       |       |                           |       |       |
| Gain Range                                   |       | -62   |                           | 0     | dB    |
| Gain Step                                    |       |       | 2                         |       | dB    |
| Phase Delay:                                 | 14    |       |                           |       | ms    |
| 8ksps  |       |       | 2.9                       |       |       |
| 16ksps                                       |       |       | 1.44                      |       |       |
| 32ksps                                       |       |       | 0.74                      |       |       |
| 48ksps                                       |       |       | 0.49                      |       |       |
| <b>Reference Clock</b>                       |       |       |                           |       |       |
| RCLK Frequency Range                         |       | 0.008 | -                         | 80    | MHz   |
| Duty Cycle                                   |       | 40:60 |                           | 60:40 |       |
| Jitter                                       | 15    |       |                           |       | ps    |
| <b>Record Digital High Pass Filter</b>       |       |       |                           |       |       |
| 4 <sup>th</sup> Order Butterworth Stopband - |       |       |                           |       | Hz    |
| 3dB point:                                   |       |       | 0.003125 x f <sub>s</sub> |       |       |
| HPSEL = 1                                    |       |       | 0.01875 x f <sub>s</sub>  |       |       |
| HPSEL = 2                                    |       |       | 0.0375 x f <sub>s</sub>   |       |       |
| HPSEL = 3                                    |       |       |                           |       |       |
| <b>Record Digital Low Pass Filter</b>        |       |       |                           |       |       |
| 4 <sup>th</sup> Order Butterworth Passband - |       |       | 0.4375 x f <sub>s</sub>   |       | Hz    |
| 3dB point                                    |       |       |                           |       |       |
| <b>Record DC Blocking Filter</b>             |       |       |                           |       |       |
| DC Attenuation                               |       |       | 90                        |       | dB    |
| <b>Playback Digital High Pass Filter</b>     |       |       |                           |       |       |
| 4 <sup>th</sup> Order Butterworth Stopband - |       |       |                           |       | Hz    |
| 3dB point:                                   |       |       | 0.003125 x f <sub>s</sub> |       |       |
| HPSEL = 1                                    |       |       | 0.01875 x f <sub>s</sub>  |       |       |
| HPSEL = 2                                    |       |       | 0.0375 x f <sub>s</sub>   |       |       |
| HPSEL = 3                                    |       |       |                           |       |       |
| <b>Playback Digital Low Pass Filter</b>      |       |       |                           |       |       |
| 4 <sup>th</sup> Order Butterworth Passband - |       |       | 0.4375 x f <sub>s</sub>   |       | Hz    |
| 3dB point                                    |       |       |                           |       |       |
| <b>Playback DC Blocking Filter</b>           |       |       |                           |       |       |
| DC Attenuation                               |       |       | 90                        |       | dB    |
| <b>PLL</b>                                   |       |       |                           |       |       |
| Start-up Time                                | 16    |       | 10                        |       | ms    |
| <b>Low Power Oscillator</b>                  |       |       |                           |       |       |
| Start-up Time                                | 16    |       | 2                         |       | μs    |
| Oscillator Clock Frequency                   |       | TBC   | 24.576                    | 30    | MHz   |

## Notes

- 14 Microphone input to speaker output with 1kHz tone  
15 RMS, cycle to cycle  
16 Following the clock start command

7.1.3.3 SPI

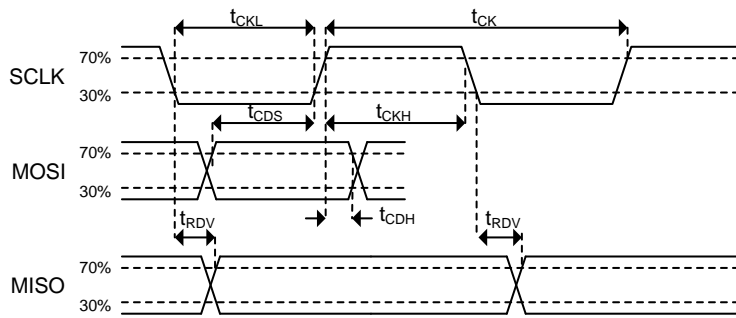
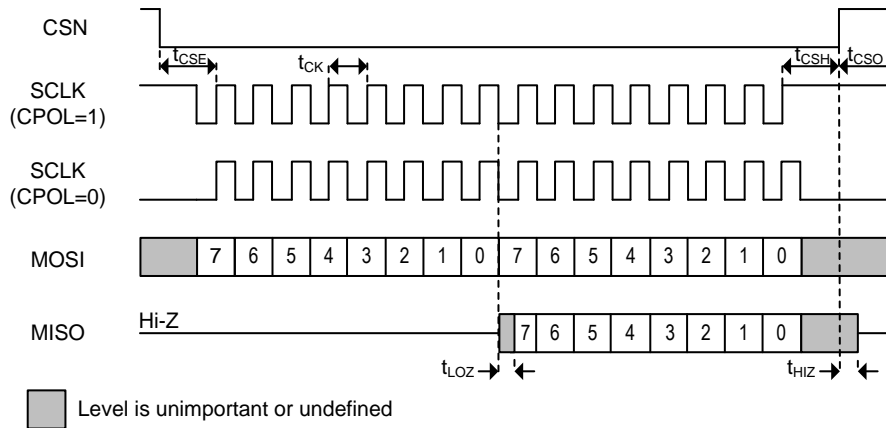


Figure 40 SPI Timing Diagram

Table 10 SPI Timing Parameter Values

| Symbol    | Parameter                             | Min. | Typ. | Max.            | Units |
|-----------|---------------------------------------|------|------|-----------------|-------|
| $t_{CSE}$ | CSN enable to clock high time         | 100  | -    | -               | ns    |
| $t_{CSH}$ | Last clock high to CSN high time      | 100  | -    | -               | ns    |
| $t_{LOZ}$ | Clock low to reply output enable time | 0    | -    | -               | ns    |
| $t_{HIZ}$ | CSN high to reply output 3-state time | -    | -    | 25 <sup>4</sup> | ns    |
| $t_{CSO}$ | CSN high time between transactions    | 100  | -    | -               | ns    |
| $t_{CK}$  | Clock cycle time                      | 100  | -    | -               | ns    |
| $t_{CKH}$ | Serial clock high time                | 50   | -    | -               | ns    |
| $t_{CKL}$ | Serial clock low time                 | 50   | -    | -               | ns    |
| $t_{CDS}$ | Command data set-up time (MOSI)       | 20   | -    | -               | ns    |
| $t_{CDH}$ | Command data hold time (MOSI)         | 10   | -    | -               | ns    |
| $t_{RDV}$ | Reply data valid time (MISO)          | -    | -    | 25 <sup>4</sup> | ns    |

<sup>4</sup> Maximum figure quoted for 10pF load on MISO.

## 7.1.3.4 TWI

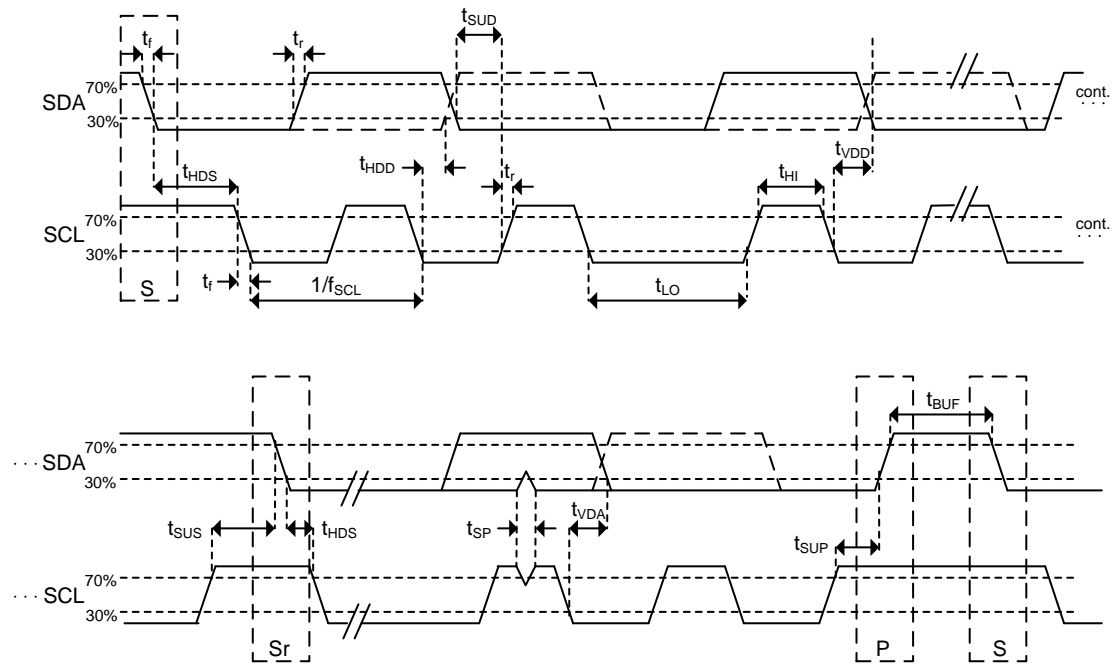


Figure 41 TWI Timing Diagram

Table 11 TWI Standard Mode Timing Parameters

| Symbol    | Parameter   | Min. | Typ. | Max. | Units   |
|-----------|---|------|------|------|---------|
| $f_{SCL}$ | SCL clock frequency                               | 0    | -    | 100  | kHz     |
| $t_{HDS}$ | Hold time (repeated) START condition              | 4.9  | -    | -    | $\mu$ s |
| $t_{LO}$  | Low period of SCL                                 | 4.7  | -    | -    | $\mu$ s |
| $t_{HI}$  | High period of SCL                                | 4.0  | -    | -    | $\mu$ s |
| $t_{SUS}$ | Set-up time for repeated START condition          | 4.7  | -    | -    | $\mu$ s |
| $t_{HDD}$ | Data hold time measured from falling edge of SCL  | 0    | -    | -    | $\mu$ s |
| $t_{SUD}$ | Data set-up time measured from rising edge of SCL | 0.25 | -    | -    | $\mu$ s |
| $t_r$     | Rise time of SDA and SCL                          | -    | -    | 1    | $\mu$ s |
| $t_f$     | Fall time of SDA and SCL                          | -    | -    | 0.3  | $\mu$ s |
| $t_{SUP}$ | Set-up time for STOP condition                    | 4.0  | -    | -    | $\mu$ s |
| $t_{BUF}$ | Bus-free time between a STOP and START condition  | 4.7  | -    | -    | $\mu$ s |
| $t_{VDD}$ | Data valid time                                   | -    | -    | 3.45 | $\mu$ s |
| $t_{VDA}$ | Data valid acknowledge time                       | -    | -    | 3.45 | $\mu$ s |
| $t_{SP}$  | Pulse Width of Suppressed Spike                   | 0    | -    | 50   | ns      |

**Table 12 TWI Fast Mode Timing Parameters**

| Symbol           | Parameter   | Min. | Typ. | Max. | Units |
|------------------|---|------|------|------|-------|
| f <sub>SCL</sub> | SCL clock frequency                               | 0    | -    | 400  | kHz   |
| t <sub>HDS</sub> | Hold time (repeated) START condition              | 0.6  | -    | -    | μs    |
| t <sub>LO</sub>  | Low period of SCL                                 | 1.3  | -    | -    | μs    |
| t <sub>HI</sub>  | High period of SCL                                | 0.6  | -    | -    | μs    |
| t <sub>SUS</sub> | Set-up time for (repeated) START condition        | 0.6  | -    | -    | μs    |
| t <sub>HDD</sub> | Data hold time measured from falling edge of SCL  | 0    | -    | -    | μs    |
| t <sub>SUD</sub> | Data set-up time measured from rising edge of SCL | 0.1  | -    | -    | μs    |
| t <sub>r</sub>   | Rise time of SDA and SCL                          | -    | -    | 0.3  | μs    |
| t <sub>f</sub>   | Fall time of SDA and SCL                          | -    | -    | 0.3  | μs    |
| t <sub>SUP</sub> | Set-up time for STOP condition                    | 0.6  | -    | -    | μs    |
| t <sub>BUF</sub> | Bus-free time between a STOP and START condition  | 1.3  | -    | -    | μs    |
| t <sub>VDD</sub> | Data valid time                                   | -    | -    | 0.9  | μs    |
| t <sub>VDA</sub> | Data valid acknowledge time                       | -    | -    | 0.9  | μs    |
| t <sub>SP</sub>  | Pulse Width of Suppressed Spike                   | 0    | -    | 50   | ns    |

**Table 13 TWI Pull-up Resistors and Bus Capacitance**

| Symbol         | Parameter                          | Min.              | Typ. | Max.              | Units |
|----------------|------------------------------------|-------------------|------|-------------------|-------|
| R <sub>p</sub> | Pull-up resistor for each bus line | R <sub>pmin</sub> | -    | R <sub>pmax</sub> | Ω     |
| C <sub>b</sub> | Capacitive load for each bus line  | -                 | -    | 400               | pF    |

Equation 1 shows the maximum value of the pull-up resistor (R<sub>pmax</sub>) is a function of the estimated bus capacitance (C<sub>b</sub>) and the maximum rise time (t<sub>r</sub>) specified in Table 11 and Table 12:

**Equation 1 Maximum Pull-up Resistor Value**

$$R_{p\max} = \frac{t_r}{0.8473 \times C_b}$$

The CMX655D supply voltage (VDD\_AD) and sink current capability (I<sub>OL</sub>) limit the minimum value of the pull-up resistor (R<sub>pmin</sub>) as shown in Equation 2:

**Equation 2 Minimum Pull-up Resistor Value**

$$R_{p\min} = \frac{VDD\_AD}{I_{OL}}$$

The value of I<sub>OL</sub> is provided in 7.1.3.1.

7.1.3.5 SAI

Figure 42 shows LRCLK/FS, SDO and SDI sampled on the rising edge of BCLK. The timing parameters also apply if the sense of BCLK is inverted.

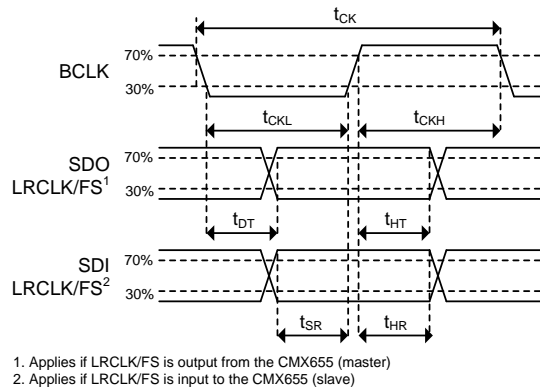


Figure 42 SAI Timing Diagram

Table 14 SAI Timing Parameters

| Symbol    | Parameter                 | Min. | Typ. | Max.            | Units |
|-----------|---------------------------|------|------|-----------------|-------|
| $t_{CK}$  | Clock period.             | 270  | -    | -               | ns    |
| $t_{CKL}$ | Clock low-time.           | 135  | -    | -               | ns    |
| $t_{CKH}$ | Clock high-time.          | 135  | -    | -               | ns    |
| $t_{DT}$  | Transmit data delay time. | -    | -    | 25 <sup>5</sup> | ns    |
| $t_{HT}$  | Transmit data hold time.  | 135  | -    | -               | ns    |
| $t_{SR}$  | Receive data set-up time. | 55   | -    | -               | ns    |
| $t_{HR}$  | Receive data hold time.   | 0    | -    | -               | ns    |

7.1.3.6 Digital Microphone Interface

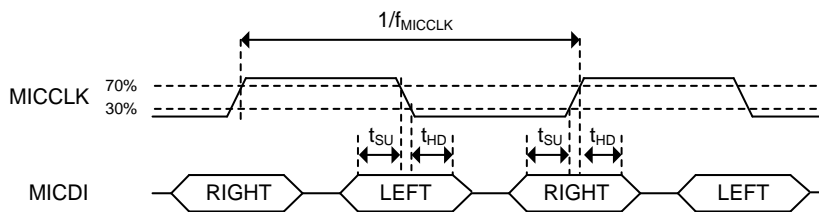


Figure 43 Digital Microphone Timing Diagram

Table 15 Digital Microphone Timing Parameters

| Symbol       | Parameter                                      | Notes | Min. | Typ.  | Max. | Units |
|--------------|--|-------|------|-------|------|-------|
| $f_{MICCLK}$ | MICCLK frequency @ 8/16/32ksps                 | 6     | -    | 2.048 | -    | MHz   |
|              | MICCLK frequency @ 48ksps                      | 7     | -    | 3.072 | -    | MHz   |
| $t_{SU}$     | MICDI set-up time before rising/falling MICCLK |       | 20   | -     | -    | ns    |
| $t_{HD}$     | MICDI hold time after rising/falling MICCLK    |       | 0    | -     | -    | ns    |

<sup>5</sup> Maximum figure quoted for 10pF load on SDO.

<sup>6</sup> If operating from LPOSC then MICCLK = LPOSC/12 so for 30 MHz maximum LPOSC the maximum MICCLK frequency is 2.5 MHz.

<sup>7</sup> If operating from LPOSC then MICCLK = LPOSC/8 so for 30 MHz maximum LPOSC the maximum MICCLK frequency is 3.75 MHz.

## 7.2 Typical Performance Characteristics

For the graphs in this section, the following conditions apply:  
 $VDD_{PA} = VDD_A = 3.3V$ .  $T_{AMB} = 25^{\circ}C$

### 7.2.1 THD+N vs. Level performance

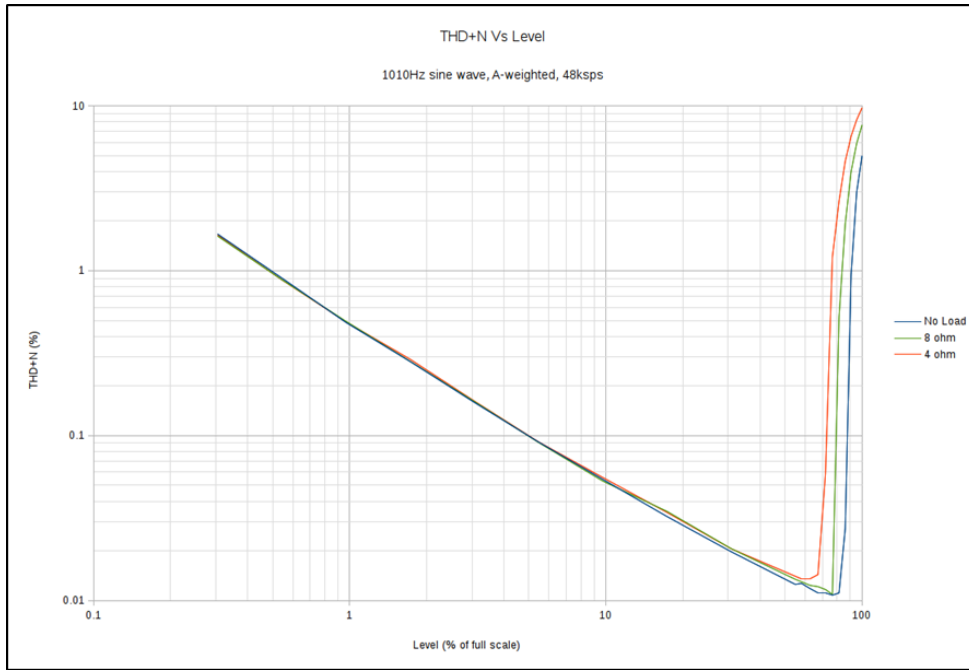


Figure 44 Class D amplifier THD+N vs. Level 48ksps

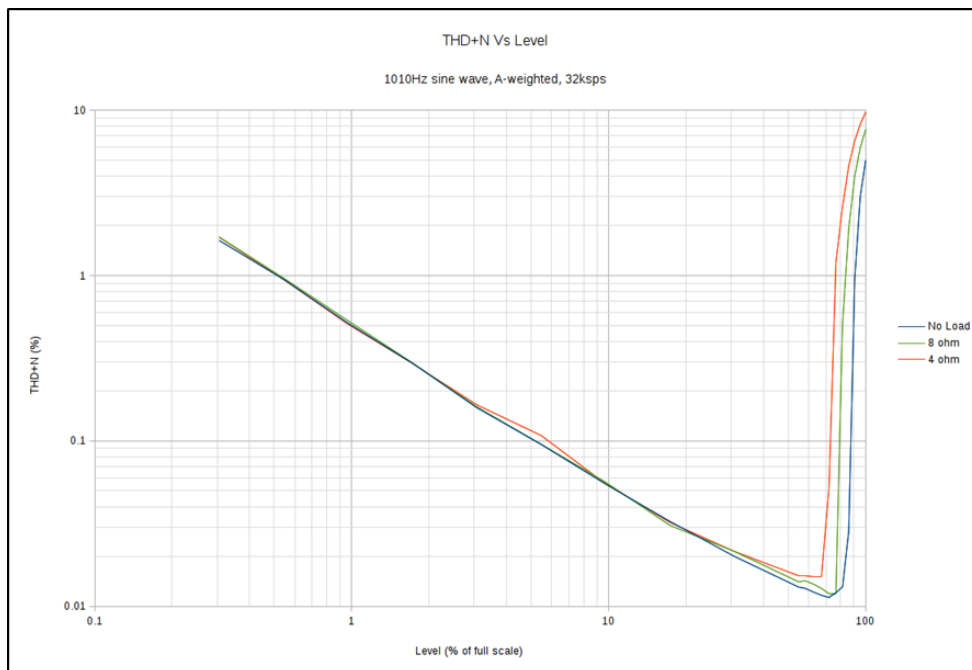


Figure 45 Class D amplifier THD+N vs. Level 32ksps

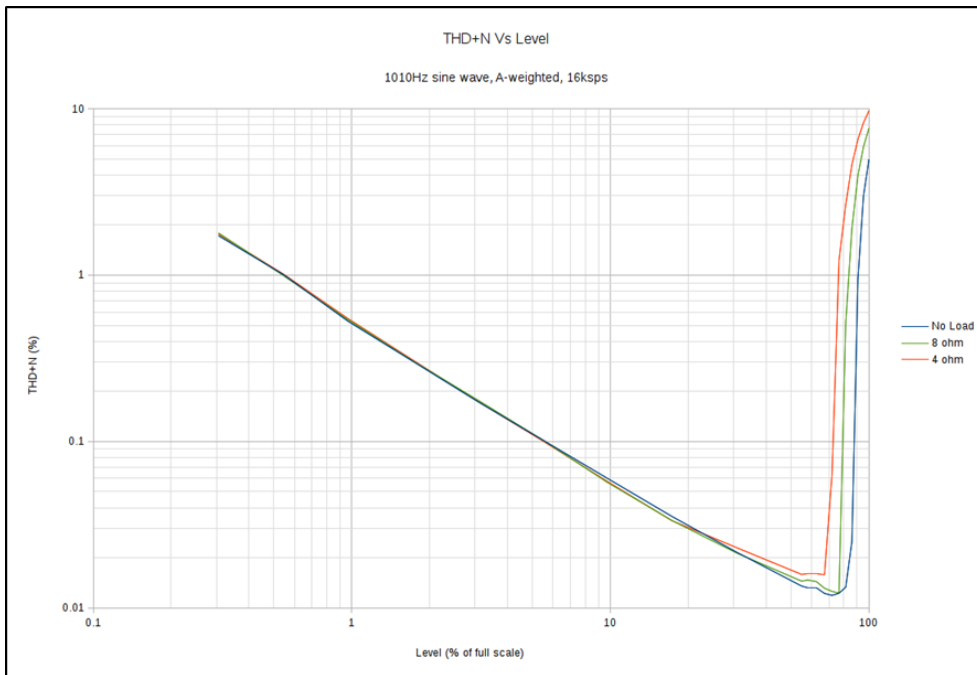


Figure 46 Class D amplifier THD+N vs. Level 16kps

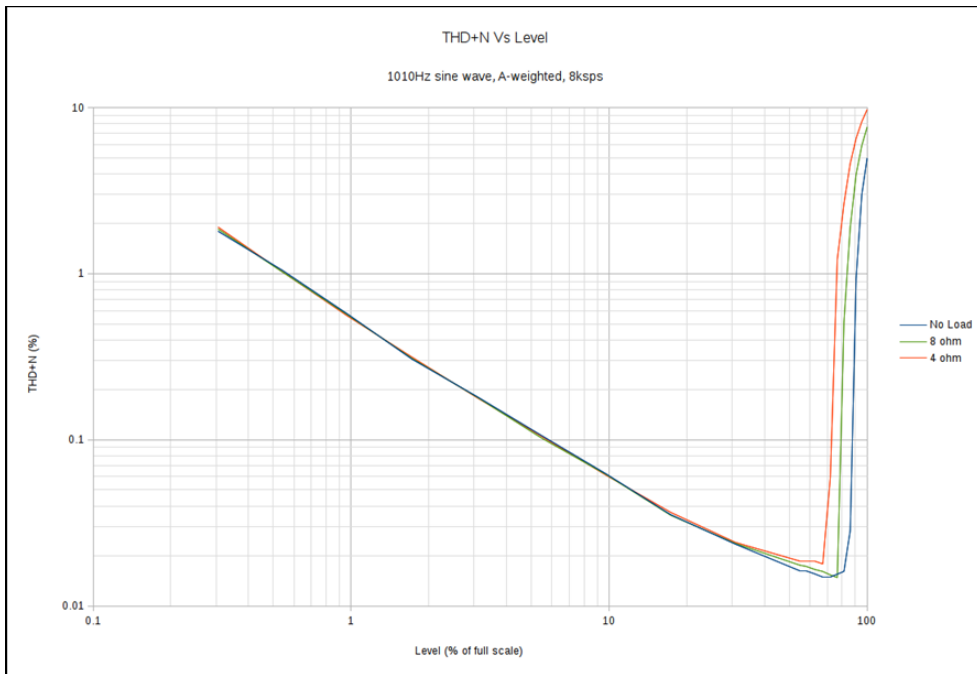


Figure 47 Class D amplifier THD+N vs. Level 8kps



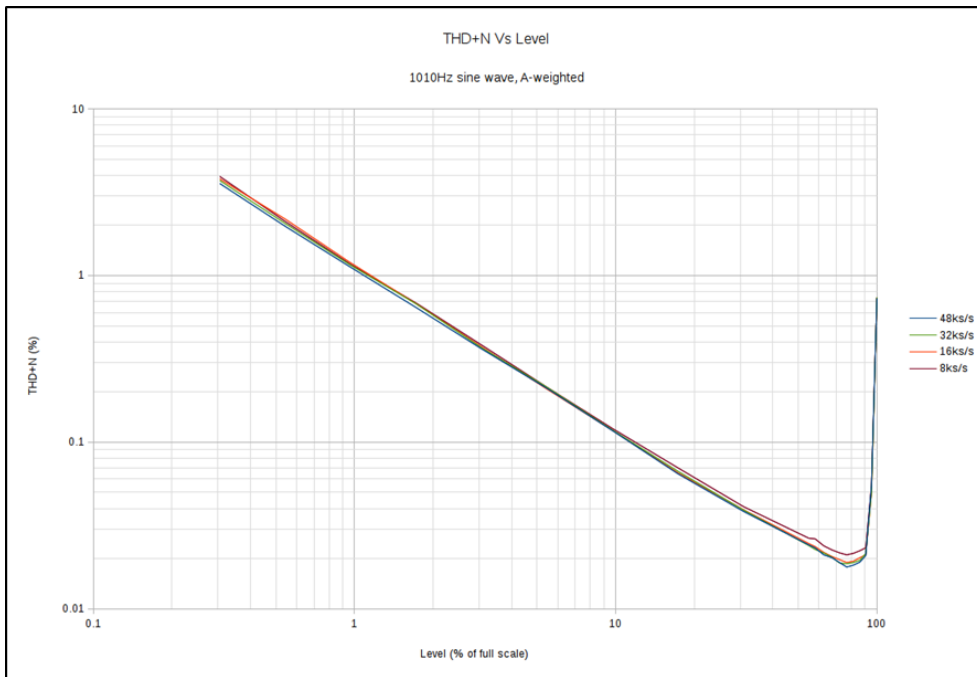


Figure 48 Line out amplifier THD+N vs. Level 48/32/16/8kps

### 7.2.2 THD+N vs. Frequency performance

As the A-weighted filter does not produce a flat response across the audio bandwidth the frequency vs THD+N plots have been reported with no filter applied.

The results are also limited to ~6666Hz to ensure the 3rd harmonic was inside the measurement bandwidth of 20kHz

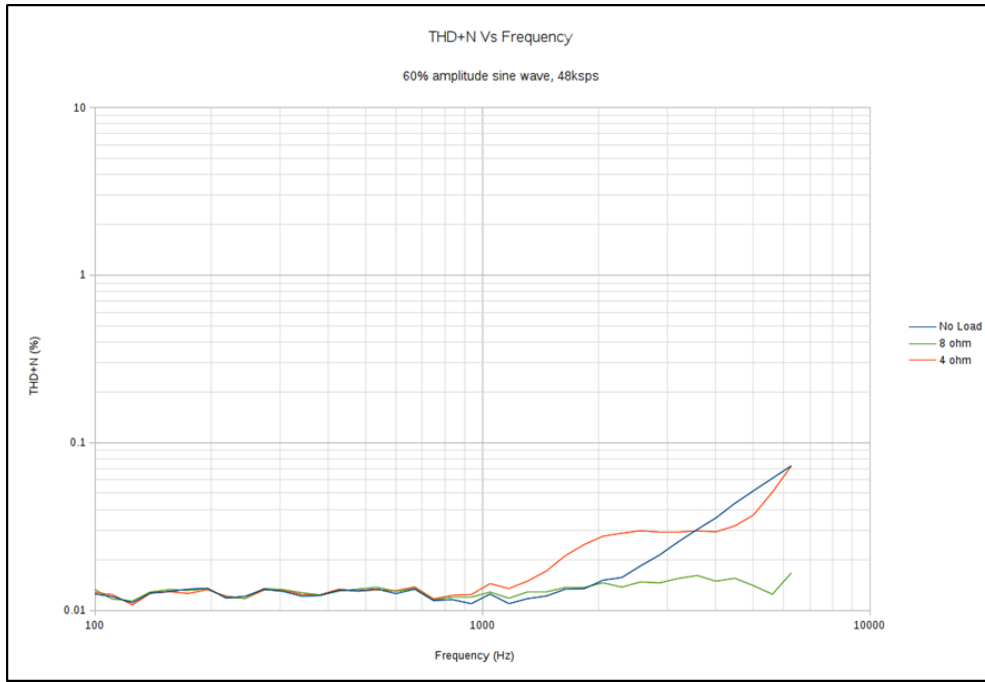


Figure 49 Class D amplifier THD+N vs. Frequency 48kSPS

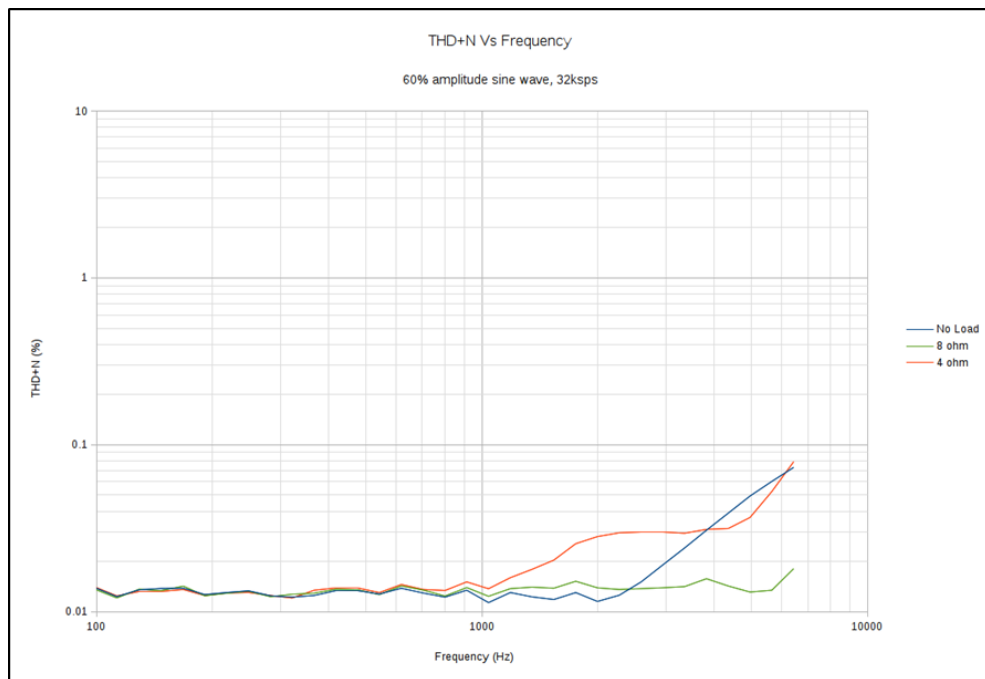


Figure 50 Class D amplifier THD+N vs. Frequency 32kSPS

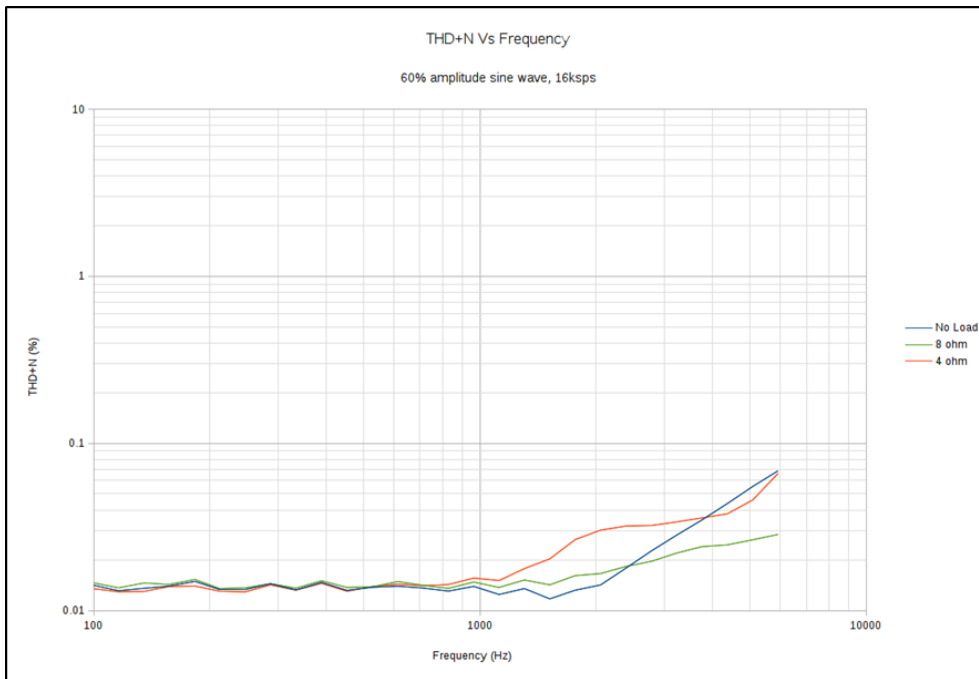


Figure 51 Class D amplifier THD+N vs. Frequency 16kSPS

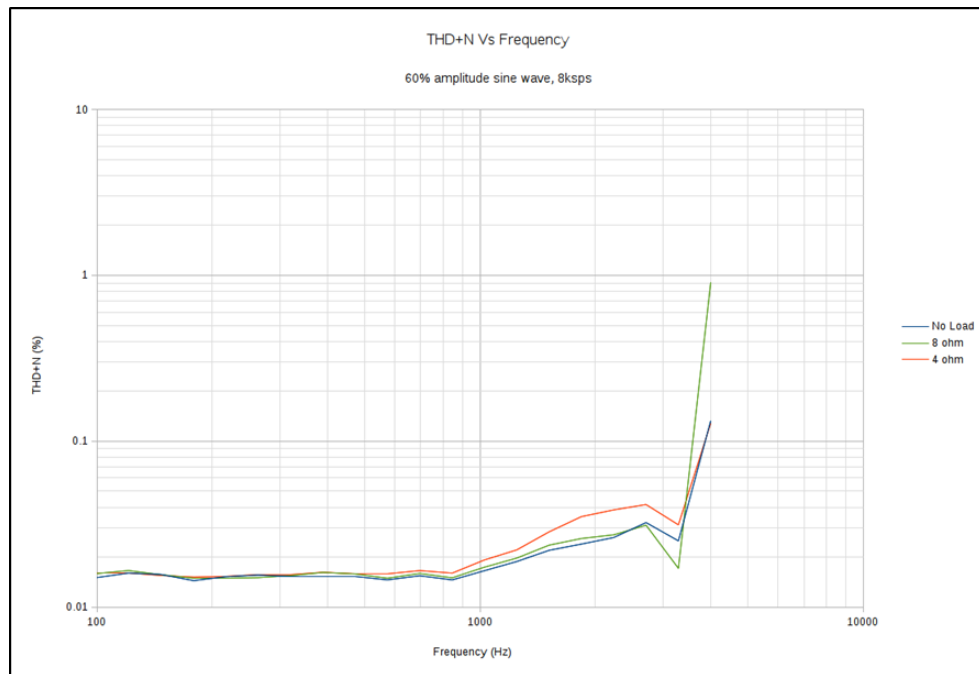


Figure 52 Class D amplifier THD+N vs. Frequency 8kSPS

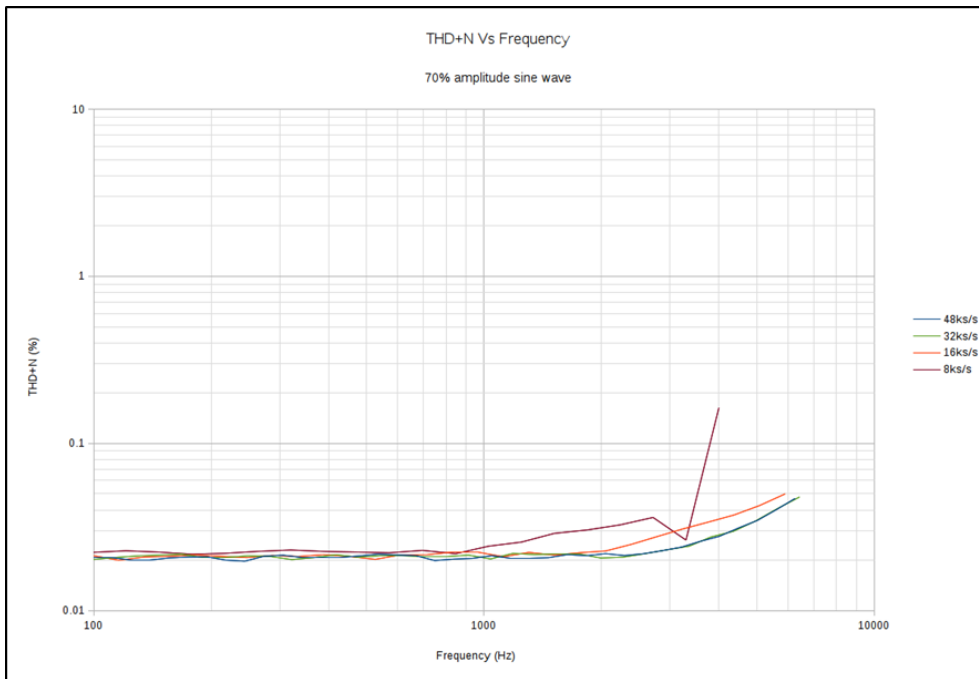


Figure 53 Line out amplifier THD+N vs. Frequency 48/32/16/8ksps

7.2.3 Class D Amplifier Efficiency

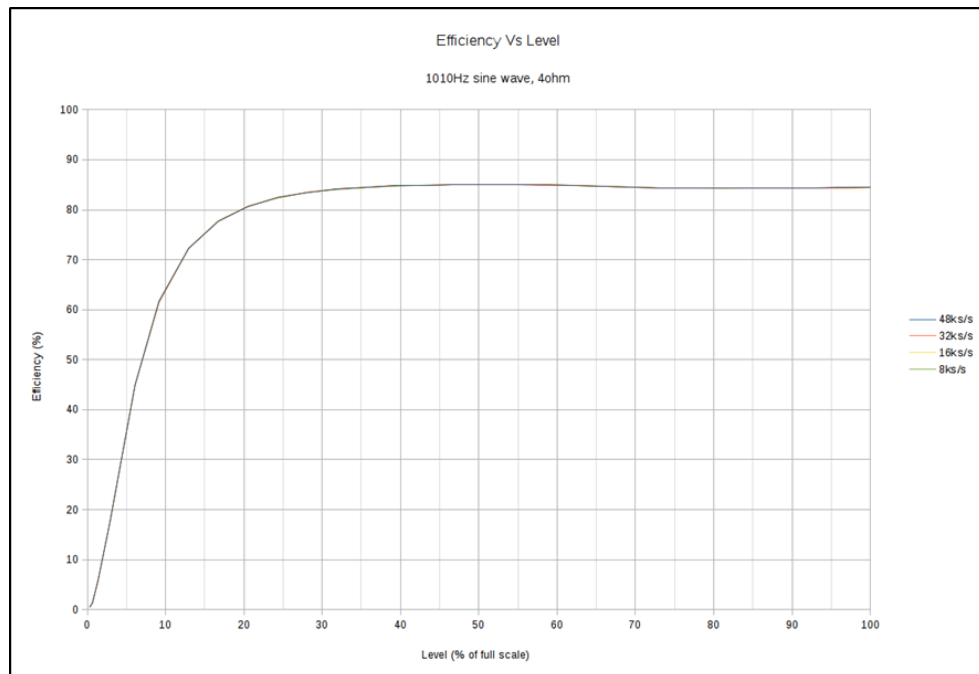


Figure 54 Class D amplifier efficiency 4Ω

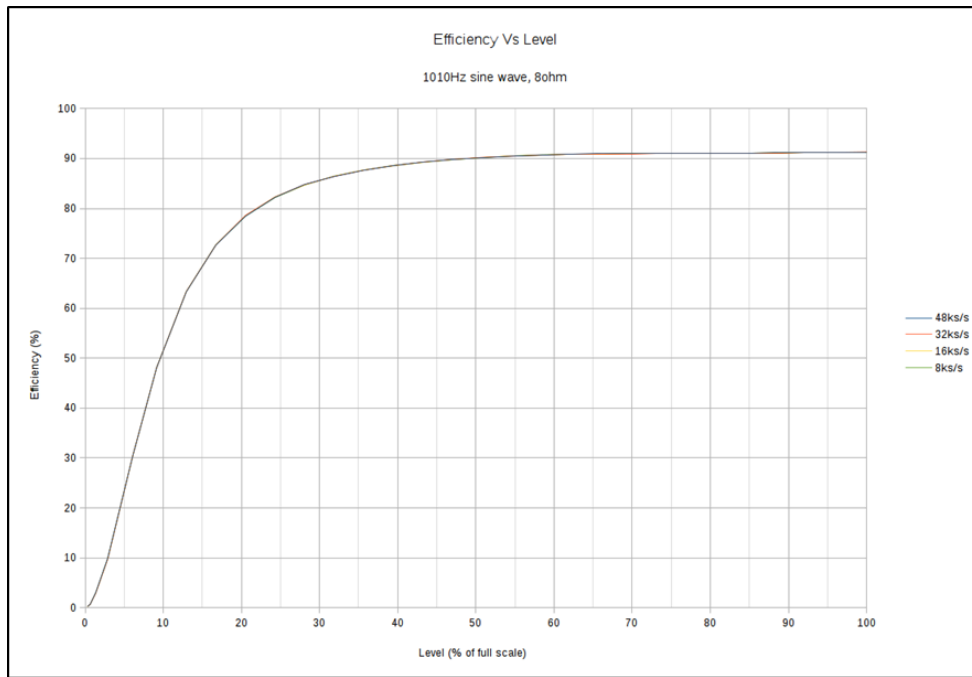


Figure 55 Class D Amplifier Efficiency 8Ω

### 7.2.4 Filter Performance Speaker Channel

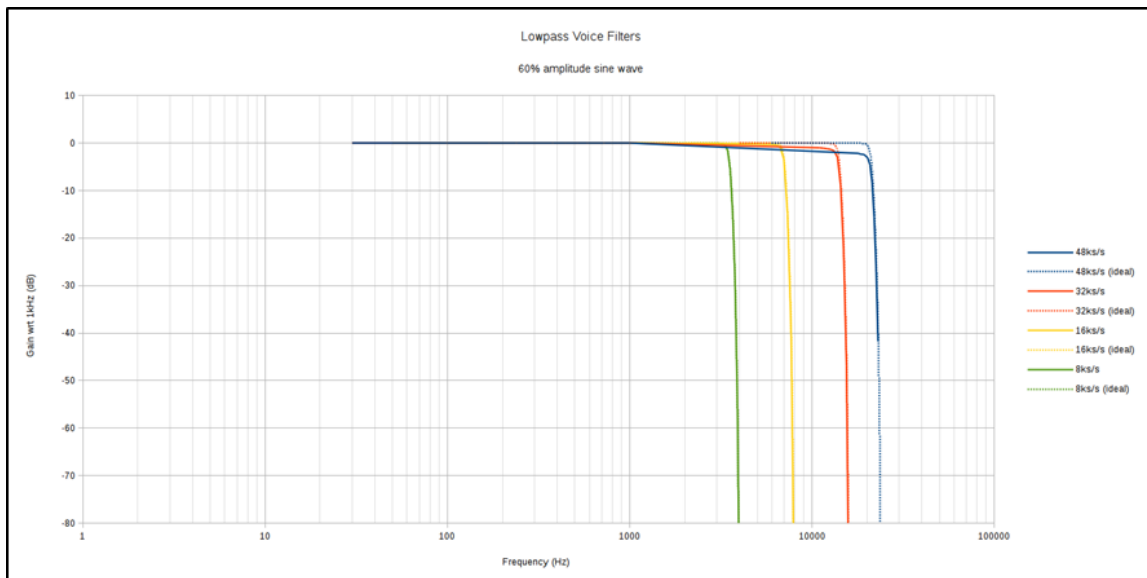


Figure 56 Low Pass Filter Response Speaker Channel

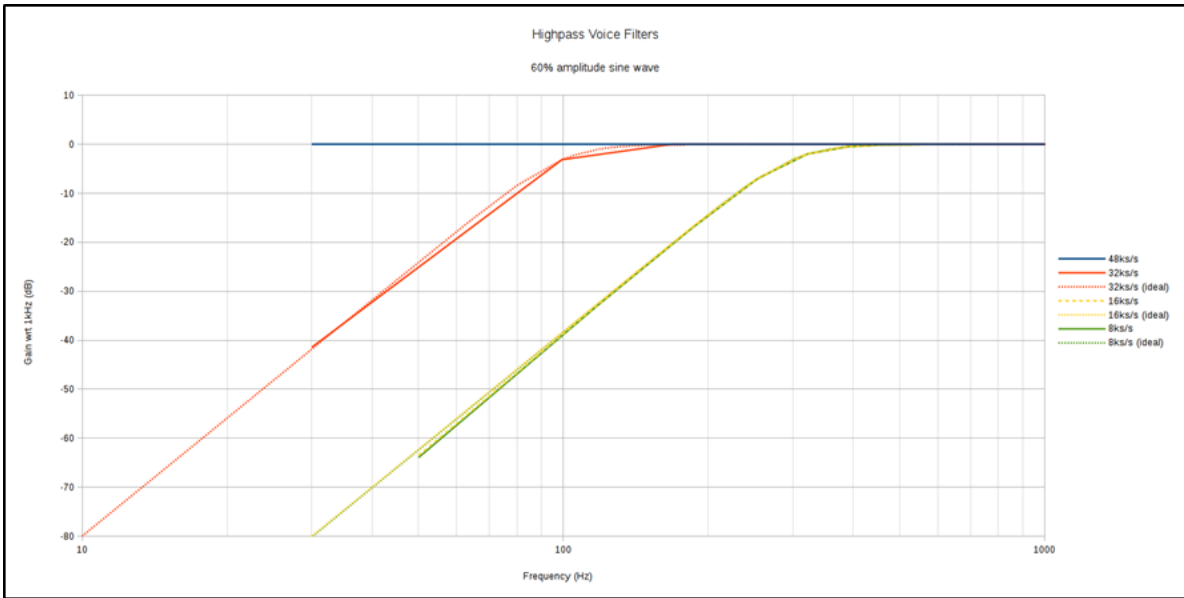


Figure 57 High Pass Filter Response Speaker Channel

### 7.2.5 Filter Performance Microphone Channel

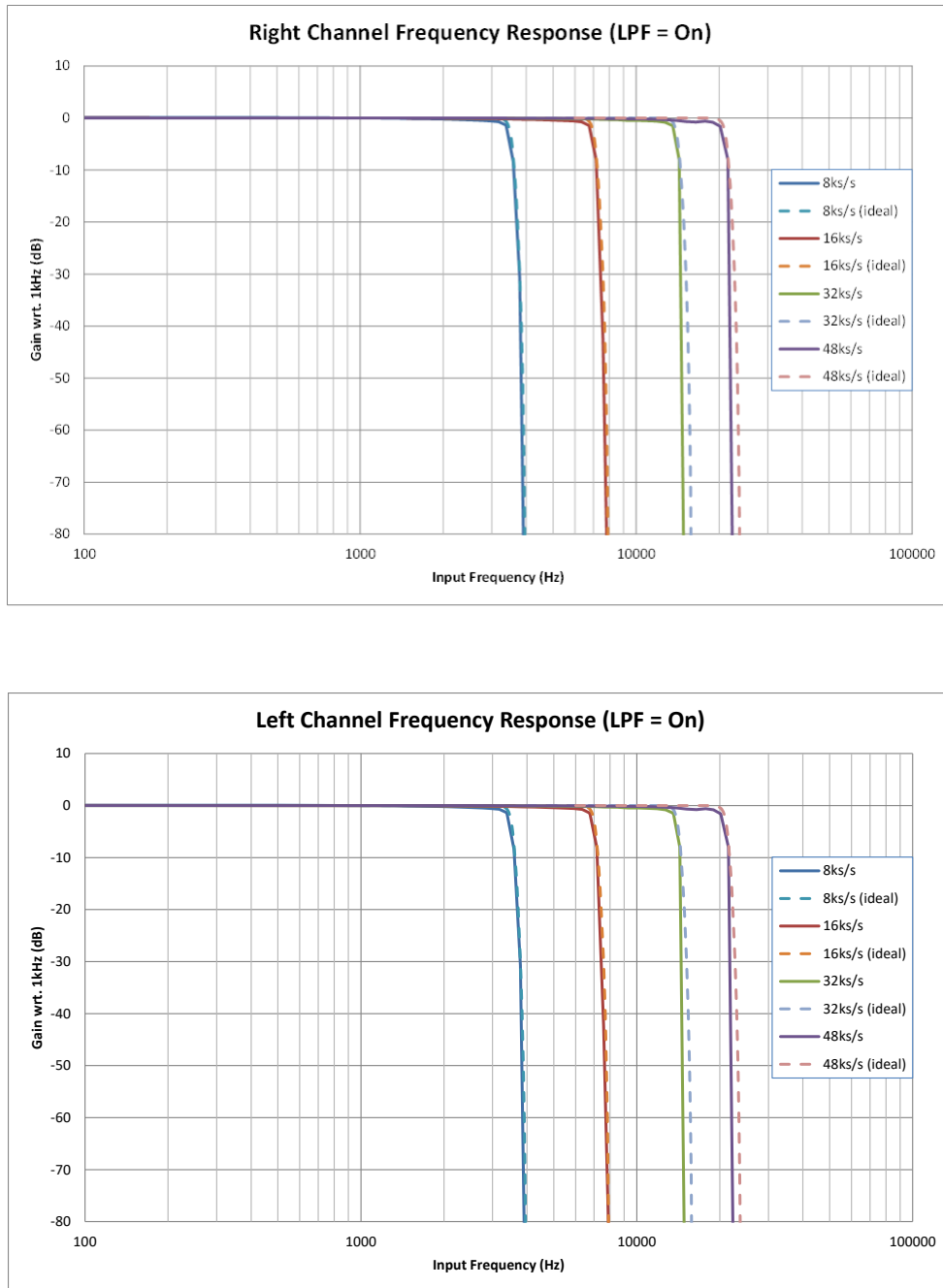


Figure 58 Low Pass Filter response Microphone Channels

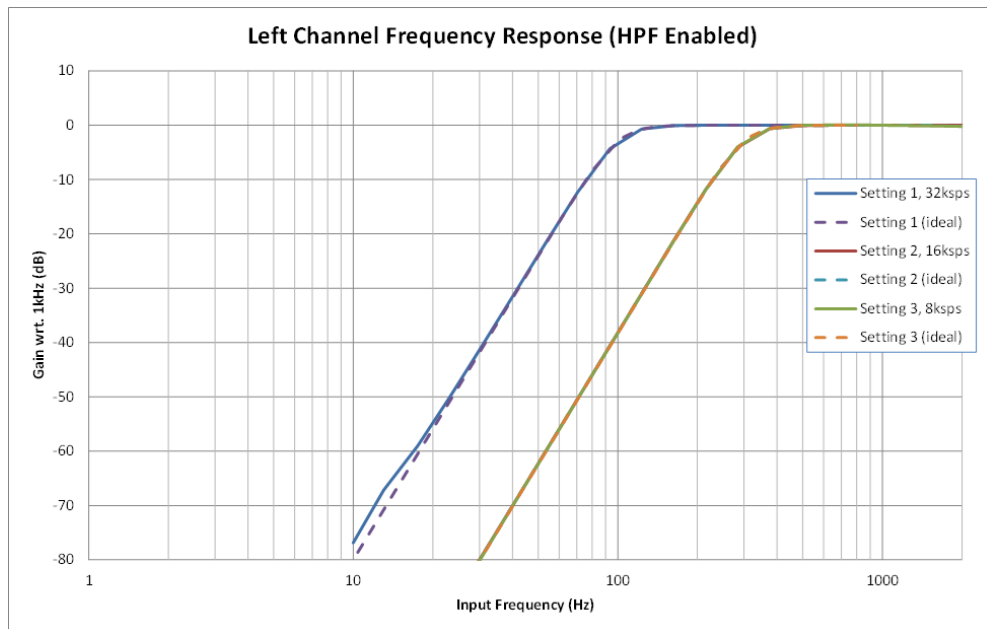
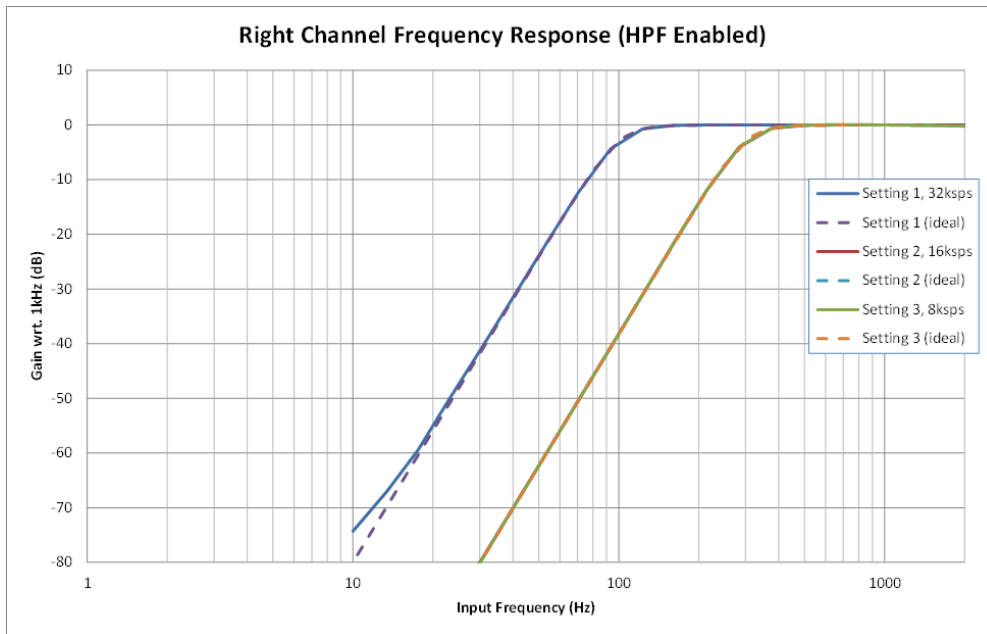


Figure 59 High Pass Filter Response Microphone Channels



7.3 Packaging

7.3.1 CMX655D

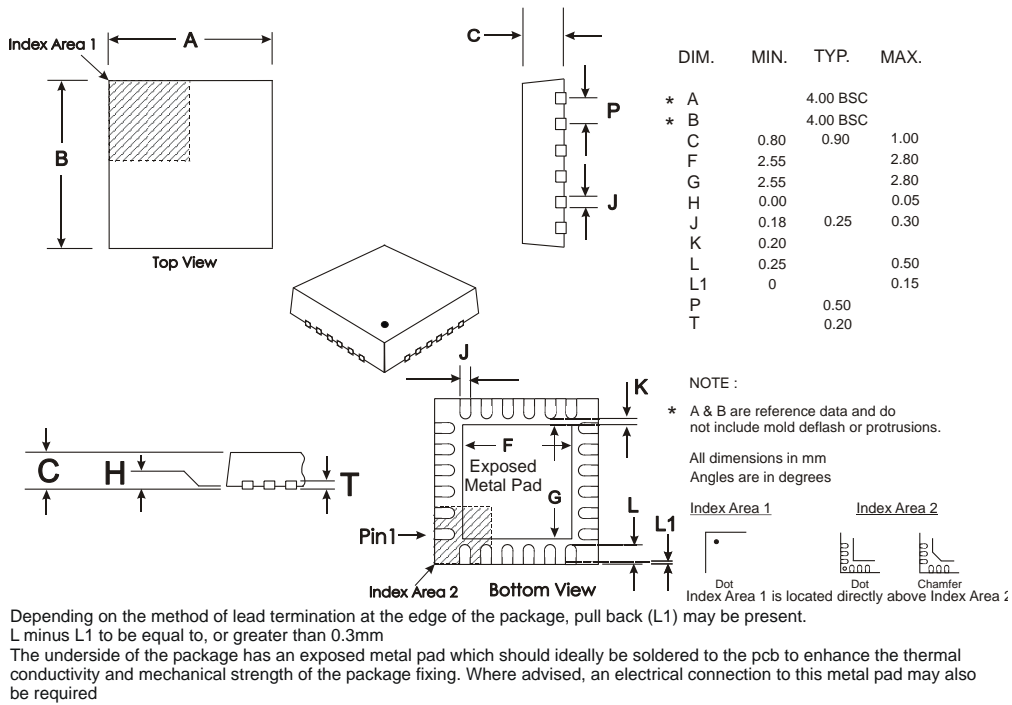


Figure 60 VQFN-24 Mechanical Outline (Q6)  
 Order as part number CMX655DQ6

Handling precautions: This product includes input protection, however, precautions should be taken to prevent device damage from electro-static discharge. CML does not assume any responsibility for the use of any circuitry described. No IPR or circuit patent licences are implied. CML reserves the right at any time without notice to change the said circuitry and this product specification. CML has a policy of testing every product shipped using calibrated test equipment to ensure compliance with this product specification. Specific testing of all circuit parameters is not necessarily performed.



|                |                        |   |
|----------------|------------------------|---|
| United Kingdom | p: +44 (0) 1621 875500 | e: sales@cmlmicro.com<br>techsupport@cmlmicro.com       |
| Singapore      | p: +65 62888129        | e: sg.sales@cmlmicro.com<br>sg.techsupport@cmlmicro.com |
| United States  | p: +1 336 744 5050     | e: us.sales@cmlmicro.com<br>us.techsupport@cmlmicro.com |

[www.cmlmicro.com](http://www.cmlmicro.com)